



CareFlex

FLEXIBILITY IN A WORLD
OF MIXED ABILITY

HydroFlex User Instructions

UI

HydroFlex Client Characteristics

The HydroFlex should be selected for clients;

- with neurological conditions who need to maintain a good, midline posture.
- with neurological conditions who require 'correct' functional positioning for rehab and activities.
- with fixed skeletal postures of the hips and spine.
- with conditions affecting their abdomen which makes upright sitting uncomfortable.
- who require a wide range of positions for different activities through the day.

The HydroFlex chair is all about keeping the client in a good, midline position. Once set up, the position is 'prescriptive' and will hold the client reasonably firmly. For this reason, the HydroFlex is not suitable for those clients with strong contractures or with pronounced pelvic windsweeping or obliquity. The HydroFlex is not suitable for highly agitated clients who will not benefit from the prescriptive support the chair offers. Unless these clients trial the chair and find it comfortable and supportive, it would be advisable to consider the softer support of the HydroTilt.

The HydroFlex is suitable for clients with neurological conditions such as MS or MND, for stroke rehabilitation and rehabilitation following spinal or head injury.

The HydroFlex incorporates features which allow it to be set up to accommodate different postures and provide seating positions for a range of activities. The key features are;

- Tilt-in-Space, which allows the clients position to be adjusted without affecting pelvic position.
- Back Angle Recline, which can be adjusted to provide a comfortable hip angle.
- Legrest elevation, to raise the legs and support the lower leg with the knees at a relaxed angle.

The suitability and effectiveness of these features are dependent on correct chair set up. Correct chair set up is dependent on three key elements; seat to floor/footrest height, seat width and seat depth.

Seat to floor height and seat width will have been measured during the initial seating assessment and the HydroFlex will have been factory assembled to these measurements. Seat depth must be adjusted to suit the client once the chair has been delivered. Seat to footplate height can be adjusted to suit the client.

Use a cloth tape measure to measure the client as you are setting up the chair. This will help limit the need for any re-adjustment.

Regularly check the HydroFlex set up to ensure it is working as intended and the client is benefiting from the pressure management solutions which are built into the chair.

These are the user instructions for the CareFlex HydroFlex chair.

Please read them carefully before setting up and using the chair and keep them in a safe place for future reference.

These instructions include details of the performance of the chair. If the chair should start behaving outside of its intended performance, show signs of damage or excessive wear, or otherwise feel unsuitable, please take it out of service and contact CareFlex or your CareFlex Distributor immediately.

The HydroFlex chair is designed for a range of clients who require a combination of comfort, pressure management and posture control from their seating system. The chair has a built-in pressure management system based on CareFlex's patented WaterCell Technology®.



Medium = 150kg max user weight.
Small = 100kg max user weight

CE Class 1
Medical Device

Pressure Management

The HydroFlex incorporates CareFlex's patented WaterCell Technology® in the seat in combination with a composite visco elastic memory foam and high elastic foam cushion. The memory foam allows the seat cushion to conform to the client's body shape, distributing their weight over as large a surface area as possible. The high elastic foam prevents the memory foam bottoming out and makes the cushion responsive to client movement. The WaterCell Technology moves with the client to ensure that the cushion remains in contact with the client as they move and alter their weight distribution.

Two lumbar options are available for the HydroFlex and each provides pressure relief in a different way. The deep laterally contoured back has kidney pads to provide simple lateral stability. These pads also increase the contact surface between client and seat, distributing their weight over as large a surface area as possible. The flat back incorporates a water cell which covers the lumbar and kyphotic spine.

These pressure relief features make the HydroFlex suitable for those clients at medium to high risk of pressure damage when used as part of a therapy programme assessed and prescribed by an appropriate Healthcare Professional.

Adjustment Control Options

There are three formats of the HydroFlex available, manual, motorised and Pro-control. On the manual version of the HydroFlex Tilt-in-Space, Back Angle Recline and the elevating legrest are controlled by locking gas actions.

On the motorised version of the HydroFlex the Tilt-in-Space, Back Angle Recline and the elevating legrest are controlled by electric actuators which are powered by a rechargeable 24V battery system.

The Pro-Control version of the HydroFlex uses actuators to control the Tilt-in-Space and legrest features but utilizes a locking gas action for the back angle recline. This is because in many situations the back angle recline needs to be set up at a specific angle for the client and should not be adjusted further. The Pro-Control system allows the healthcare professional to set up the back angle recline and leave the day to day adjustments of TIS and legrest elevation to the client/carer.

Fixed and Loose Covers

The HydroFlex is available with either fixed or loose covers. The fixed cover version has a cleaner, crisper appearance to make what is essentially a clinical product look more appropriate in a domestic environment. The fixed cover greatly reduces the need for Velcro on the chair, which may make the chair more appropriate in areas where infection control is a significant consideration. The loose cover version has greater flexibility in terms of adjusting the chair's configuration and carrying out servicing and repair procedures.

Identification

Each HydroFlex chair has a unique chair number which must be quoted during any correspondence with CareFlex or your local CareFlex Distributor. This number is on a silver foil label on the cross bar of the seat depth adjustment frame at the back of the chair. The number is essential for tracing the product and allows accessories and spare parts to be easily selected.

I. Chair Set-up

Ia. Seat Height & Width

If the client can raise to standing themselves or with minimal assistance, the seat height should be set so that the client's feet rest flat on the floor and the underside of their thighs are in contact with the full length of the seat cushion. If the seat height is too high, the client's heels will be lifted off the floor and pressure will build up along the underside of their thighs. If the seat is too low, their knees will be raised and there will be no contact between the back of their thighs and the seat cushion. This will increase the pressure on their bottom and sacrum and could cause discomfort at the hips.

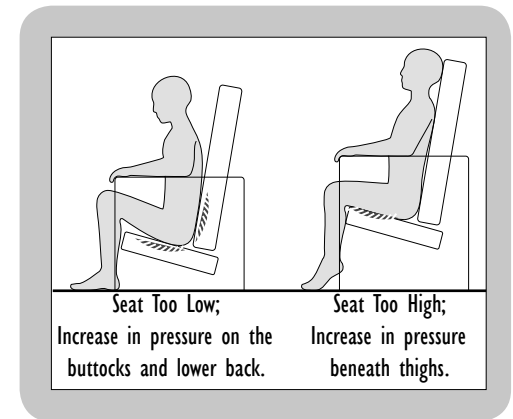

If the client is less ambulant and is being regularly portered then seat height can be set relative to the footplate. Again, ensuring the foot is flat and fully supported is important.

Seat width affects side-to-side pelvic stability. This is important as the spine should line up centrally with the pelvis. If the pelvis is free to move to one side then the client's spine will usually lean in the opposite direction. As gravity pulls the client over, the spine will begin to curve to compensate as the client tries to keep their head level. The client will take on a characteristic 'S' shaped spine or scoliosis. The more upright the user's trunk is, the more critical pelvic stability becomes. It is, therefore, important to use a chair with the correct seat width in order to position the pelvis properly.

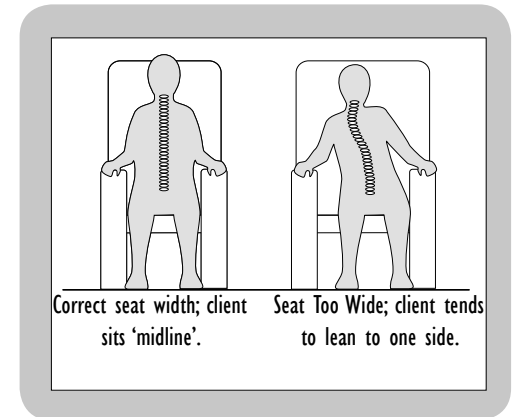

Seat width should always allow for a little bit of movement as the client's body weight and posture naturally shifts throughout the day. If the client is held in a rigid position they will quickly tire and experience discomfort.

HydroFlex seat height and width will have been measured during assessment and the chair made to these dimensions for the client prior to delivery.

If further adjustment is required, please contact your local CareFlex Distributor.

Ib. Seat Depth

It is important to set seat depth correctly in order to prevent 'sacral sitting' and to achieve the best distribution of weight between the client and the chair. Sacral sitting occurs when the pelvis tilts backwards so that the lower back (sacrum), as well as the bottom, is resting on the seat cushion. The sacral area can be susceptible to pressure problems. Sacral sitting will occur if the seat depth is too long. If the seat depth is too short then the client's body weight will be concentrated in too small an area.

Seat depth should be set with the client's bottom positioned firmly at the back of the seat cushion so that their lower back and lumbar is supported by the back cushion. There needs to be a two or three finger gap between the client's calf and the front of the seat cushion for comfort.

If the client already has a chair or wheelchair with the correct seat depth, measure this size and use it to set up the HydroFlex.

Seat depth is adjusted by moving the back of the chair over the seat unit. The front edge of the seat will stay in the same place. The seat depth mechanism is controlled by a release lever on the rear left hand underside of the seat.

To adjust seat depth, twist the seat depth release lever clockwise. Hold one of the curved tubes of the seat back frame and push/pull the back to the desired position.

Once the back is in the correct position let go of the lever. The back may 'jump' back slightly as the locking mechanism engages.

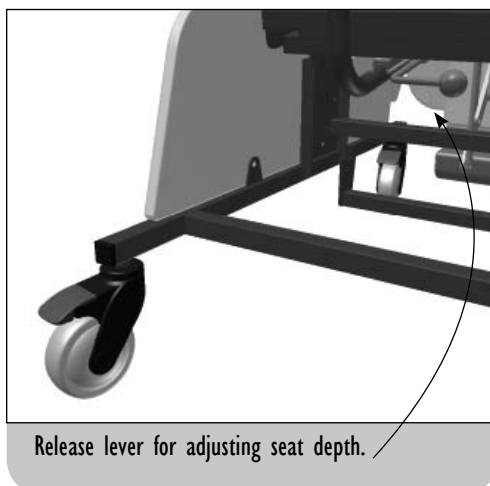
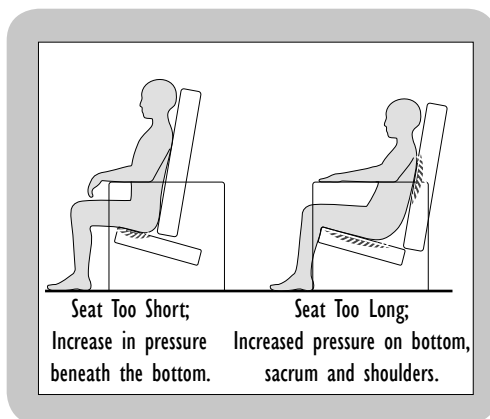

Release lever for adjusting seat depth.

Seat depth should not be adjusted when a client is sat in the chair or when the chair is tilted backwards.

Ic. Back Angle Recline

The HydroFlex has Back Angle Recline (BAR). BAR is used to adjust the angle between the seat and back, thus changing the angle of the client's hips.

When the back is fully upright, the angle at the client's hips will be approximately 95°. However, because of the contoured profile of the back, the client will find this a comfortable position for mealtimes, activities and for preparing to raise to standing.

The back angle can be reclined to give a 125° angle at the hips. This is a comfortable position for resting.

Id. Back Angle Recline Adjustment

Caution has to be taken when adjusting BAR to provide a comfortable and stable sitting position. If misused, BAR can lead to an unstable seating position where the client can easily slide out of the chair or quickly slide into sacral sitting. Both sliding actions could lead to pressure damage through shear.

Ideally, BAR should be altered very occasionally to suit client condition. For regular changes of position it is best to use the TiS facility, as this can be adjusted without affecting pelvic stability. BAR may be disconcerting for some clients. Please ensure the client is comfortable and does not become distressed if they are fully reclined backwards.

Ie. Back Angle Recline Fully Motorised Version

On the motorised HydroFlex BAR is controlled by the handset. The third row of two buttons control BAR. The right hand button reclines the back. The left hand button returns the back to its upright position.

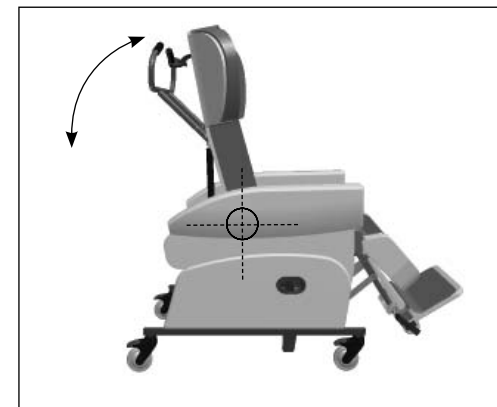

Back Angle Recline (BAR), where hip angle can be adjusted.

Always warn the client before changing back angle to ensure they do not become distressed or agitated.

If. Back Angle Recline Manual & Pro-control

A small lever located on the centre of the push bar controls Back Angle Recline. This lever is hidden by a valance cover to prevent the BAR being accidentally activated. As mentioned above, BAR has a fundamental affect on seating position and must only be adjusted by those who understand how to achieve a good sitting posture.

To adjust the back angle recline, undo the valance from the underside of the push bar to reveal the small BAR lever. Squeeze the lever gently to unlock the gas action controlling BAR and allow the back to be tilted to the required angle. When the client is in a comfortable position, let go of the lever and the back angle will lock in position. Re-position the valance cover to hide the BAR lever.

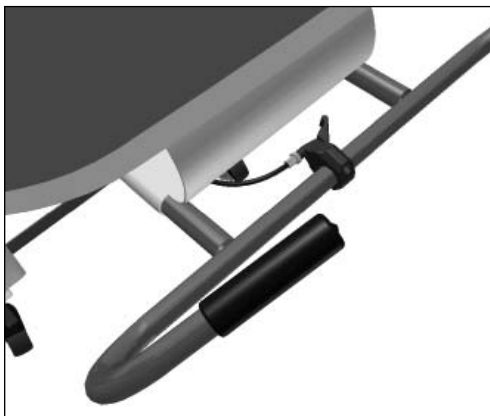

BAR lever hidden under push bar valance.

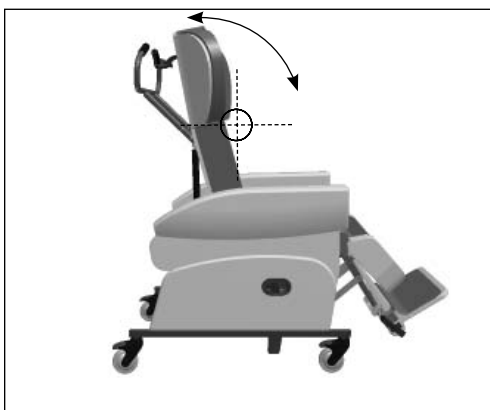

Leg Elevation, where knee angle can be adjusted.

Ig. Articulating Back

The Articulating Back allows for profiling of the back to accommodate kyphosis and more complex head positioning issues. The top section of the chair back can be angled through a range of 35° forward of its upright position in 5 indexed steps.

Ig. Articulating Back

There is a two stage adjustment to the Articulating Back mechanism. Firstly, the locking wheel needs to be released. This is located on the right side of the back frame where the push bar is attached to the back frame. Turn the locking wheel through two complete turns to free the mechanism.

The second stage is to pull out the indexing pin on the left side of the back frame. The top section of the back can now be angled. Once in position to support the client's head and shoulders, release the indexing pin and feel for it clicking into place. Re-tighten the locking wheel to eliminate any wobble in the mechanism.

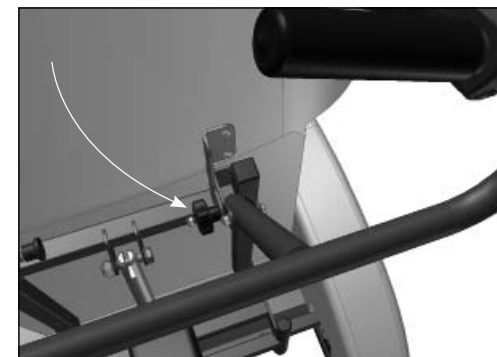

Undo the locking wheel first...

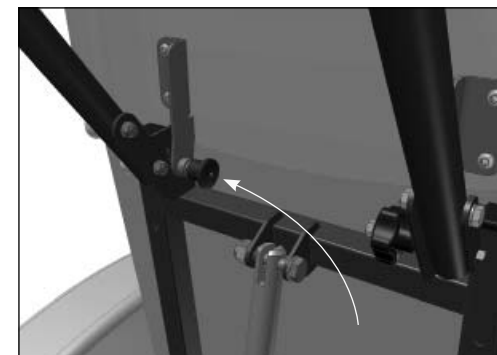

...& pull out the indexer on the left to adjust angle.

3. Day to Day Use

3a. Brakes

Before transferring in and out of the chair the brakes on the castors should be activated. The castors have a full brake which locks roll and swivel. Always ensure that at least two of the castor brakes are applied before a client transfers in or out of the chair.

To apply the brakes begin by generally positioning the chair. Once the chair is in the desired position push it forward slightly. This will swing the rear castors around to reveal the brake levers. Press down the end of the levers to lock the brakes. To release the brakes, gently kick the top of the brake lever so that it clicks flat.



Brake lever on rear castor.

Do not attempt to push the chair with the brakes applied as this can damage the castors and stress the frame of the chair.

3b. Elevating Legrest

The HydroFlex has an integral legrest which can be angled up to support the legs. The legrest articulates, following the movement of the knee as it elevates the legs.

The legrest incorporates visco-elastic memory foam for pressure relief.

Ensure the legrest is fully lowered before transferring a client to or from the chair.

The range of Legrest elevation is from 80° at the knees to 170°. The comfort of legrest elevation is often determined by hip angle. Over-elevating the legs can cause tightness in the hamstrings which could cause discomfort, especially if the BAR has been set up so that the hip angle is close to 90 degrees.

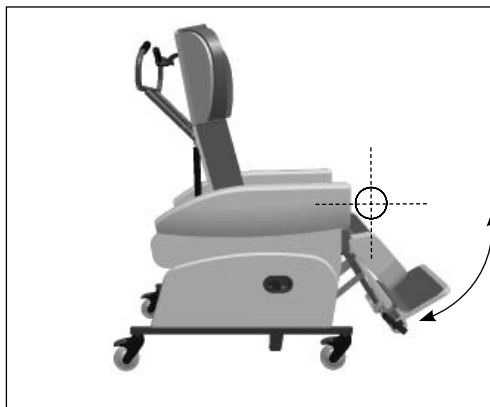

Leg Elevation, where knee angle can be adjusted.

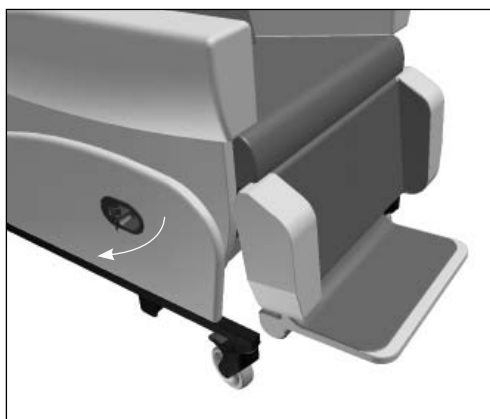

Release lever for legrest elevation.

3d. Motorised & Pro-control

On the motorised and Pro-control options, legrest elevation is controlled by the handset. The top row of two buttons control Legrest elevation. The left hand button raises the legrest. The right hand button returns the legrest to its lowered position.

3d. Integral Footplate (cont.)

The legrest has an integral height and angle adjustable footplate to provide support to the client's feet when the legrest is raised or when they are being portered in the chair. The footplate is stored behind the top section of the legrest. Lift the top section of the legrest and the footplate will drop down. To lock the footplate in its primary, 90° angle, pull the lever on the right side of the footplate sideways. The footplate has three angle settings to provide comfort and support plantarflexion. As the legrest is elevated, having a 90° angle at the ankle will become more uncomfortable. The footplate can be angled down to provide a more relaxed position. To adjust the angle pull the lever on the right side of the footplate sideways. Tilt the footplate to the desired angle and release the lever. The lever will slide into the nearest angle setting.

To fold the footplate up and store it behind the top section of the legrest, pull the lever on the right side of the footplate sideways and raise the footplate up. Lift the top section of the legrest, push the footplate fully up and lower the top of the legrest to hold the footplate in place.

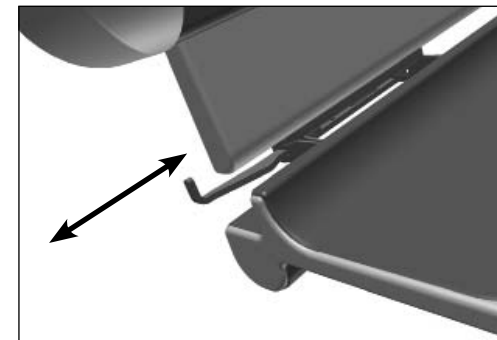

Pull the lever sideways to adjust footplate angle.

SAFETY NOTE

It is essential to regularly check the adjustment of the footplate to ensure it does not hit the ground when lowered. When the chair is tilted backwards it is possible to extend the legrest length so that it is greater than the seat to floor height. However, if the chair is tilted forward when the legrest is fully extended the footplate may hit the floor and damage the legrest mechanism.

3e. Seat to Footplate Height

Seat to footplate height can be adjusted by pulling out the indexing pin located on the (client's) right hand side of the legrest assembly. Pull out the indexer and raise/lower the footplate to the desired height relative to the seat. Once at the desired height, release the indexer. The indexer will click into the nearest height setting and lock the footplate height.

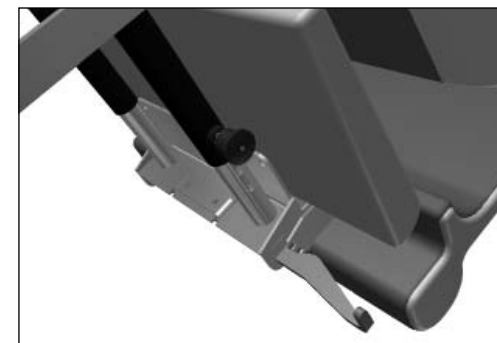

Indexing pin to set the seat to footplate height.

3f. Tilt-in-Space (TiS)

The HydroFlex has a Tilt-in-Space facility which allows the client to be reclined without adjusting the angle at the hips.

This helps the client to maintain a stable sitting posture whilst distributing their weight over a large surface area.

Tilt-in-Space should be regularly adjusted to facilitate an easy change in weight distribution, thus avoiding pressure build up in any one area.

Always warn the client before changing Tilt-in-Space to ensure they do not become distressed or agitated.

The chair will Tilt-in-Space 30° backwards. This degree of tilt may be disconcerting for some clients. Please ensure the client is comfortable and does not become distressed if they are fully tilted backwards.



Tilt-in-Space, where seat to back relationship stays the same as the chair tilts.

3h. Tilt-in-Space, Fully Motorised and Pro-control

On the motorised and Pro-control option the Tilt-in-Space is controlled by the handset. The second row of buttons control Tilt-in-Space. The right hand button tilts the chair back. The left hand button returns the chair to its upright position.

NOTE: The HydroFlex has a large range of Tilt-in-Space. When the chair is fully upright, the seat surface will be level with the floor, encouraging the client into a standing position.

3g. Tilt-in-Space Manual Option

On the manual option the TiS feature is controlled by the large lever on the push handle.

To adjust the TiS, squeeze the lever and tilt the chair to the desired angle. Release the lever to hold the chair at the desired angle.

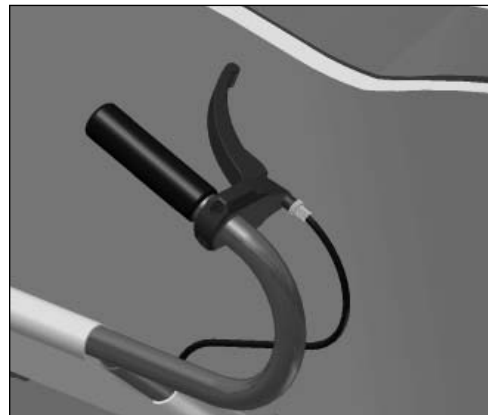

Tilt-in-Space lever, manual HydroFlex.

3i. Back Wings

The top section of the HydroFlex back has adjustable wings to help upper trunk positioning. The wings are angle adjustable and can be used to help stabilise headrest position, provide support to the shoulders or change the shape and support offered by the soft pillow headrest accessories.

The wings can be angled in to provide close support for the client or opened out if the client is broad across the shoulders or does not want to feel restricted.

To adjust wing angle, open the zip closures at the top of each side of the back cover. A small recess houses an indexing pin controlling wing angle. Lift the top of the indexing pin to release the wings and adjust them to the desired angle. Once at the desired angle, release the index and allow the pin to lock into the nearest setting.

After adjusting wing angle, fasten the velcro closure so that the cover sits neatly.

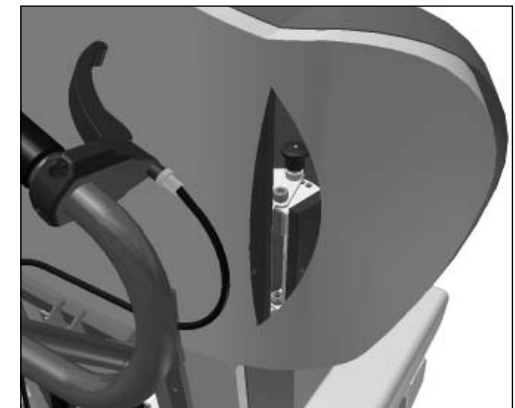

Open the sides of the back cover to reveal the indexer for wing angle adjustment.

SAFETY NOTE

When tilting the HydroFlex forward, ensure the footplate height is set so that the footplate will not hit the floor.

4. Fully Motorised & Pro-Control Chairs

The Pro-Control HydroFlex uses actuators to adjust the Tilt in Space and legrest elevation. The fully motorised HydroFlex uses actuators to adjust the Tilt in Space, Legrest elevation and Back Angle recline. Both systems utilize a 24V DC rechargeable battery system which needs to be regularly charged in order to maintain battery performance.

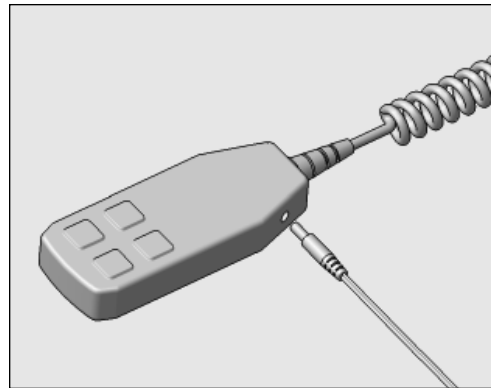

Plugging the charger jack into the socket on the side of the handset.

4a. Batteries and Charging

When a motorised chair is first delivered and before it is used, charge the batteries for twelve hours to ensure they are at full power. Similarly, if the motors have not been used for a prolonged period, charge the batteries for twelve hours to bring them up to full power. Establish a regular regime for battery charging. Charging the chair regularly overnight is recommended. The battery unit will sound a warning signal when the battery is nearing its minimum recommended charge level. Charge as soon as is practicable once this signal is heard.

Only chargers supplied by CareFlex should be used to charge CareFlex chairs. Do not use a CareFlex charger to charge other products.

- Fit the jack plug connected to the charger into the socket on the hand control unit of the chair.
- Plug the charger into a 240V AC mains electric supply and switch on the power to the charger. See the notes above for charge times.
- At the end of the charging cycle, switch off the charger and disconnect all leads and plugs.

NOTE: AutoTilt chairs have a different location for attaching the charger. See the AutoTilt section for details.

When disconnecting the cable, always pull the moulded body of the plugs straight out of the socket. Do not pull the wire as this may damage the cable and the socket.

DO NOT:

- **leave the chair connected to the mains with the mains power switched off.**
- **move the chair when it is connected to the mains.**
- **charge the batteries when there is a client in the chair.**

If, after charging, the motor actuators do not work, take the chair out of service immediately and contact CareFlex or your local Distributor.

4b. Using a Chair with Motorised Actuation

A chair with motorised actuation has a hand controller on a coiled flex attached to the control box on the chair. To activate the actuators and tilt the chair, elevate the legrest or recline the back, depress the appropriate up or down button for the facility required.

Always warn the client before making any adjustment to the chair so that they do not become agitated or confused.

4c. AutoTilt Facility

The Pro-Control and fully motorised HydroFlex chairs are available with an AutoTilt facility. This has been developed to enhance the pressure management already found in the HydroFlex and to make more efficient use of the nursing care and time needed to achieve good pressure care.

The AutoTilt reduces the amount of carer input by automatically adjusting the chair at timed intervals. Every 45 seconds micro-processors move the HydroFlex through 0.5° of Tilt-in-Space in order to continually re-focus the pressure points on the body. The AutoTilt starts at any position through the tilt cycle. Once activated the chair will tilt backwards to the maximum tilt position before tilting forwards to approximately halfway through the tilt cycle. The chair will not come fully upright during the AutoTilt cycle but will change direction to tilt backwards from the halfway point. A full AutoTilt cycle lasts 16 minutes.

The AutoTilt will repeat this cycle for either one or eight hours, ensuring optimal pressure care for those that need it most.



Handset for Pro-Control HydroFlex.

4d. AutoTilt in Use

AutoTilt chairs are fitted with an eight button handset. For Pro-Control versions, the buttons indicating Back Angle Recline adjustment (3rd row) do not function.

By depressing the bottom left button the one hour AutoTilt cycle will begin. Pressing the bottom right button activates the eight hour cycle. If the chair is fully upright it will begin to tilt backwards at the intervals described above.

Pressing any of the function buttons on the handset will interrupt and stop the AutoTilt cycle.



8 button handset for all HydroFlex AutoTilt chairs.
NB: 3rd row of buttons are not used on Pro-Control chairs.

4e. AutoTilt Battery Charging

The HydroFlex AutoTilt control box is charged directly from the supplied 24V charger. There is a small jack socket on the back edge of the control box where the supplied 24V charger needs to be fitted.

The control box has a safety cut out to stop the batteries being fully discharged. Once the working load voltage drops below 21V the unit will not work. Put the chair on charge for twelve hours and do not operate the chair when it is on charge.

The TiS motor makes a small beeping noise when it moves. This is a harmonic resonance caused by the soft start program used to reduce the amount of 'bounce' in the movement of the AutoTilt.

The control box has been programmed to 'back off' at the minimum and maximum strokes of the motors and if the motors sense an overload, e.g. if the legrest was elevated against a wall. If the motors automatically 'back off', release the button being depressed on the handset and press the opposing button to re-set the unit.

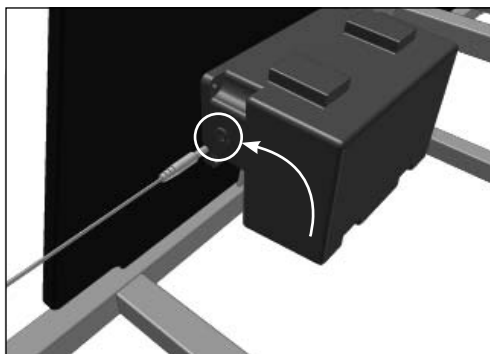

Connect the charger to the socket on the back edge of the AutoTilt control box.

5. Options and Accessories

5a. Transfer Arm

The transfer arm option makes side transfer easier, either from a bed or wheelchair. The arm can be tilted up and back to give clear access to the seat.

The transfer arm should only be used when the seat is fully upright. A locking wheel beneath the front outside edge of the arm cushion locks the transfer arm in place.

Undo the wheel by a couple of turns and lift the arm up from the front. As soon as the front of the arm lifts up it can be slid back and pivoted so that it hangs down at the back of the chair.

Once the client has transferred to or from the chair, the arm can be tilted and pushed forward so that it re-engages with the lock at the front of the chair.

Tighten the locking wheel to lock the arm in position.

Do not grab or attempt to support weight on the transfer arm once it has been put into the transfer position.



Undo the locking wheel to release the transfer arm.



Transfer arm tilted back to give access for side transfer.

5b. Pelvic Straps

Please note, pelvic straps :

- Are an aid to maintaining a good posture and client safety.
- Must not be used as restraints.
- Must be adjusted to comfortably support the user and not restrict body function or cause discomfort.
- **A client must be supervised by suitably trained personnel at all times if they are using a pelvic strap.**

5b. Pelvic Straps

The two parts of the buckle on the straps click together. To release the buckle, press the tabs on the sides of the buckle and pull the two halves apart.

A pelvic strap is attached to the seat depth frame of the HydroFlex behind the seat cushion. The strap is fitted through the gap between back cushion and the chair arms and across the client's hips at a 45° angle. This strap position is intended to keep the pelvis in an upright position by pulling the user as far back into the seat as possible. It is essential that the strap is always correctly adjusted. Regularly check the tension of the strap so that the client is correctly supported and cannot wriggle beneath, or otherwise become trapped by the strap.

The buckle on the strap is adjustable from both sides which helps to keep the buckle located centrally. To tension the pelvic strap, pull the loose ends of the webbing straps coming from the buckles.

The pelvic strap with sub-ASIS pads should be used if the client is sensitive to pressure across the bony ridges on the front of their pelvis.



Pelvic strap with buckle adjusting from both sides.

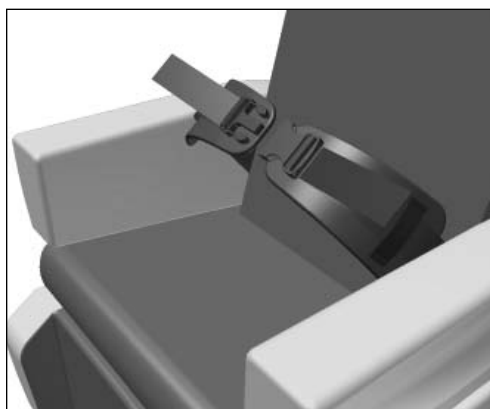

Pelvic strap with sub-ASIS pads.

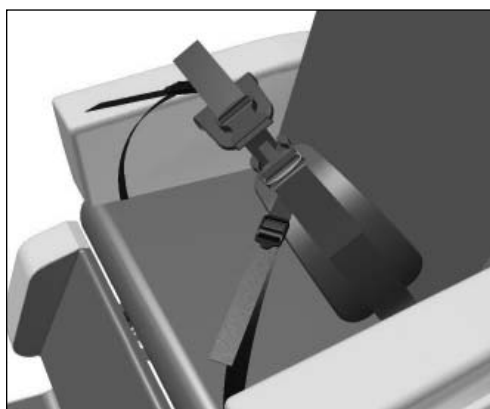

4-point pelvic strap.

5c. 4-point Pelvic Strap

The 4-point pelvic strap offers greater stability as secondary straps keep the strap at the correct height across the pelvis. The secondary straps come down over the sides of the thigh and attach to the underside of the seat. The secondary straps have individual adjustment to help keep the main strap positioned at the correct height.

Once the main strap is correctly positioned the secondary straps should be tensioned to prevent the main strap moving upwards. To adjust the secondary straps, pull the loose ends of the webbing straps fitted through the ladder lock buckles.

5d. Headrest Types

The Profiled Soft Headrest is a simple pillow of soft material which will conform to the shape of the client's head but which will provide limited lateral control.

The CareFlex InLine headrest provides full cranial support beneath the occiput and above the ears. This headrest incorporates memory foam to help reduce incidences of pressure problems on the ears, cheeks, lower jaw and side of the head. The InLine headrest is intended to support the head and neck in a neutral position to help the client swallow and manage saliva.

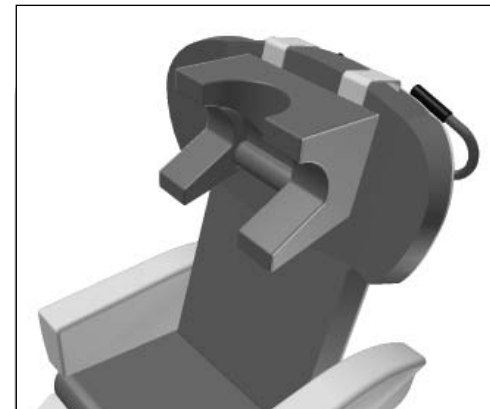

InLine headrest.

5e. Headrest Set-Up

The set up of the profiled soft headrest comes down to client comfort. The bottom points of the headrest can be positioned over the clients shoulders to provide additional side support.

The InLine Headrest should be set up so that the bottom edge of the headrest is level with the top of the client's shoulders.

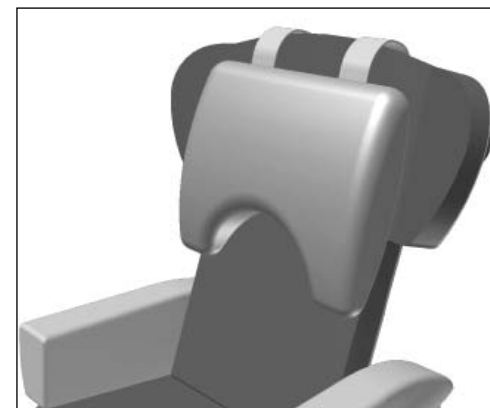

Profiled soft pillow headrest.

5f. Headrest Positioning-Loose Cover

Height is controlled by straps coming off the top edge of the headrest and attaching to velcro closures on the back of the back cushion cover. The height of the headrest should be set to provide comfortable support. Try not to push the client's head forward or allow it to tip back as this will affect the client's ability to swallow and will cause discomfort.

The wings of the chair back can be adjusted to provide greater lateral support for the headrest. See the earlier instructions for guidance.

5g. Headrest Positioning- Fixed Cover

On the fixed cover version of the HydroFlex, the headrest is positioned on 'turn buckles'. These are fittings attached to the back of the headboard over which eyelets in the headrest strap are hooked.

Turn the buckles so that they are lined up vertically to un-hook the eyelets and adjust the strap. Fit the eyelets back on to the turn-buckles so that the headrest is held at the appropriate height and turn the buckles through a quarter turn to hold the straps in place.

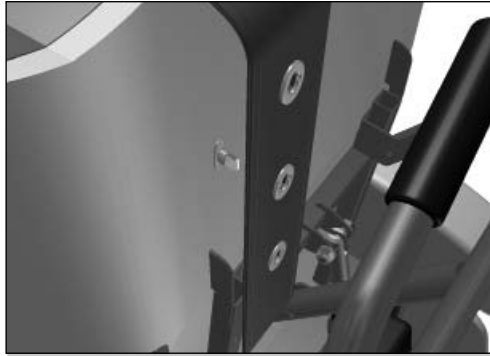

The turn buckles hold the headrest straps in place on the fixed cover version of the chair.

5h. Adjustable Laterals

The adjustable laterals should be used to counter any tendency for a client to lean to one side. They are not suitable for more active clients who are able to manage their own posture or who tend to rock backwards and forwards or who are ataxic.

Two types of pad are available for the HydroFlex adjustable lateral system.; regular pads and kidney pads. The regular pads have a regular, deep 'D' with an angled face at the back to fit around the chest to provide a large support area. The regular pads can be fitted either side of the chair.

Kidney pads come as a left and right hand pair. These have a tear drop profile and a larger, angled contact surface which gives less prescriptive support. To discern left from right, position the kidney pad laterals as if they were on a chair. The more pointed end should be towards the top of the pad with the rounded end indicating the bottom of the pad.

The adjustable laterals can be adjusted up and down and in and out to provide the necessary support. They adjust individually and so can be set up to suit an asymmetric posture such as scoliosis.

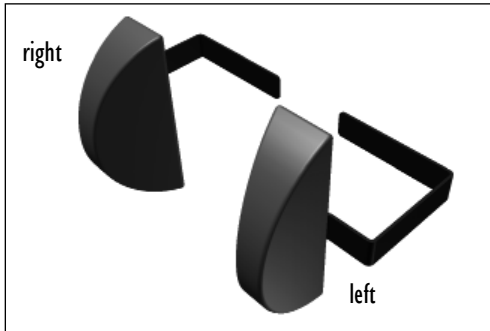

Kidney pad adjustable laterals, more pointed end upwards to make a handed pair.

Lateral supports are intended to provide firm support for the client's trunk. They may not be appropriate for those clients who are susceptible to pressure damage around their ribs. If the client is susceptible to pressure damage the laterally contoured back option may be more appropriate.

Lateral supports are usually adjusted so that they are supporting the client's thorax (upper chest). The laterals must be adjusted so that the majority of the lateral is above the client's lower rib. There is no point in fitting the laterals against the sides of the client's abdomen or just above their waist as these areas are flexible and the client will end up leaning over the pad. For comfort leave a three finger gap between the top of the lateral and the client's armpit.

Before transferring the client into the HydroFlex take a measurement of the height of any lateral support they have fitted to a wheelchair or activity chair. Otherwise, try to measure from seat to mid chest height. The laterals can then be adjusted to this height prior to transferring the client to the chair.

Similarly, measure the distance between the lateral supports on the client's wheelchair or across their chest so that the width between the laterals can be set up before transfer.

To adjust lateral height, pull out the lower knob on the adjustment block fitted to the back of the chair back. This knob controls the indexing pin which locks into the holes in the height adjuster. Raise or lower the lateral pad to the desired height and release the knob. Push the lateral down until the indexing pin is felt to lock in place.

Width is controlled by the clamp plate on the adjustment block. Turn the handwheel on the adjustment block until the lateral is free to slide sideways. Once in the desired position tighten the handwheel to lock the pad in place.

If the HydroFlex is to be used without the adjustable laterals undo the handwheel controlling the width adjustment and slide the laterals completely out of the adjustment blocks. Keep the laterals in a safe place for future use.

Please refer to the later instructions to retro-fit the Adjustable Lateral System.

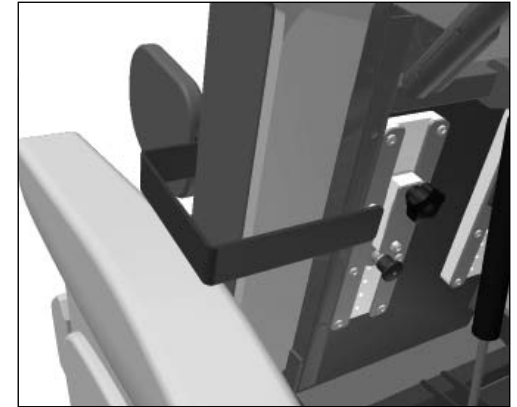

Fit the lateral armature into the adjustment block.

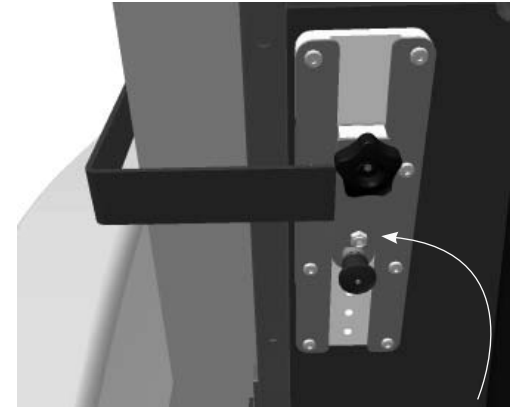

Pull out the lower knob to adjust lateral height.

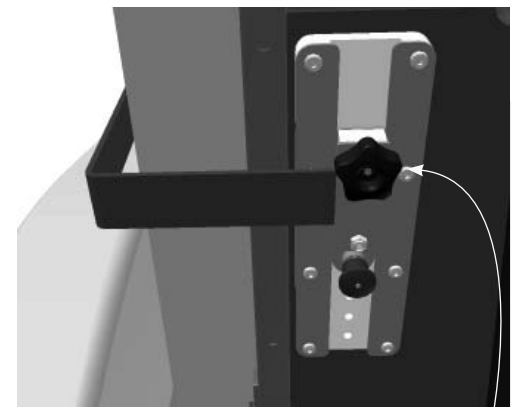

Turn the handwheel to adjust lateral width and tighten the handwheel to hold the setting.

5i. Four point Chest Harness

A four point chest harness keeps the user in an upright and 'midline' position and is very effective at controlling lateral movement. However, their use must be carefully considered, especially if the client has a stoma or feeding device implanted in their abdomen. A four point harness should never be used as a restraint.

The harness consists of a padded bib shape held in position with a strap from each corner. Two straps attach to the chair at the client's waist and two over their shoulders. The straps are attached to the harness with side-lock buckles. The length of the webbing straps can be adjusted through the buckles.

To use the harness undo one of the lower buckles and both buckles which fit over the shoulders. Hang the bib section of the harness over the side of the chair and position all straps so that the client cannot sit on them when they are transferred into the chair. Transfer the client into the chair, position the bib section of the harness in front of them and fasten the buckles at the waist and shoulders. Ensure the belts are sufficiently tight to help support the client but are not tightened to the point where they restrict breathing or cause discomfort.

The four point chest harness is fitted to a web which fits over the back of the HydroFlex. Fasten the buckles on the top of the web around the push handle and bolt the A plates on the bottom of the web onto the pelvic strap mounting holes in the seat depth frame. Tension the web by pulling tight the webbing on the buckles attached around the push handle.

Slide the tri-glides on the web to the level of the clients shoulders to hold the shoulder straps at the correct height.



Four point chest harness.

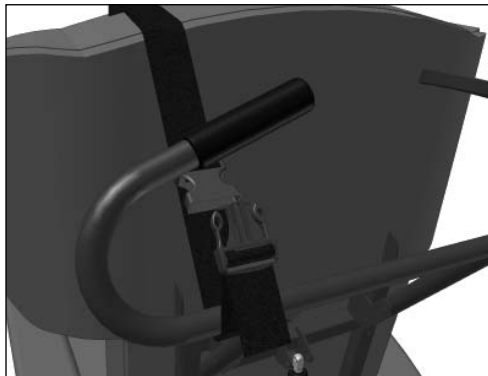

Fit the buckle closures at the top of the harness around the push handles.

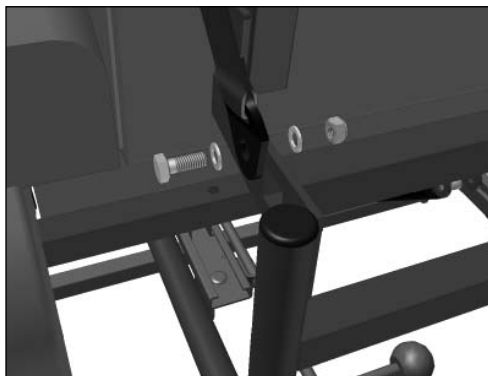

Fit the A plates at the bottom of the harness to the seat depth frame.

5k. Pommel

A pommel can be used to control knee position, usually by abducting (pushing apart) the knees to help keep the seating position stable and level. The pommel is designed to separate the knees and support the whole inside of the knee joint. For this reason the pommel is not depth adjustable and sticks out in front of the seat edge.

A pommel must never be used as a restraint and the client must not be allowed to slide into sacral sitting and come to rest against the pommel.

Fit the pommel with the legrest angled down as this will give the best access to the bracket.

To fit the pommel, locate the cut-out in the bottom front edge of the seat cushion. The opening for the pommel bracket is located in this cut-out. Fit the metal stem of the pommel into the bracket and push the pommel until it is felt to click into position.

To remove the pommel, hold it at the bottom edge of the metal stem and pull directly outwards.

5l. Anterior Knee Strap

Only used in conjunction with the pommel, the anterior knee strap fits across the front of the knees, preventing the client sliding forward and helping to keep the pelvis in the back of the seat. The anterior knee strap can be used as an alternative to a groin harness to help maintain client position.

The strap must cover the whole of the knee (not sit below it) and should not be used by clients with damaged hip and/or knee joints or those with a history of hip and/or knee pain.

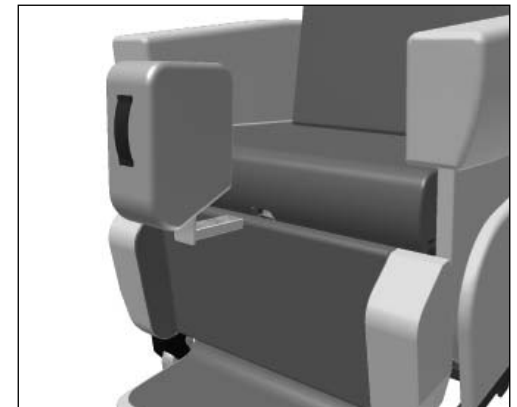

Fit the pommel into the bracket in the middle of the bottom edge of the seat.



Fit the tab on the inside face of the knee strap through the loop on the front of the pommel.

A tab on the inside face of the knee strap fits through the webbing loop on the front of the pommel and closes onto a velcro patch. This controls the height of the strap relative to the pommel.

The padded strap is attached to the pommel and attaches to the connectors on the sides of the chair with a two part buckle (See further instructions for fitting connectors).

Fasten the two parts of the buckle and tension the straps as necessary.

The anterior knee strap must not be used as a restraint.

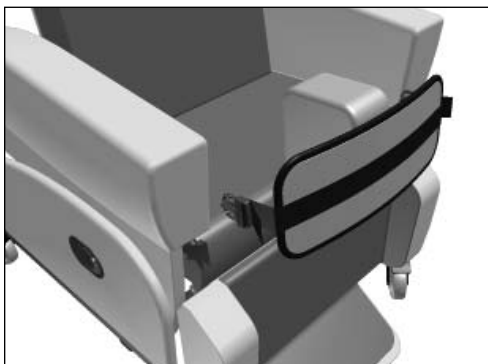

Connecting the buckles on the sides of the knee strap to the connectors attached to the chair.

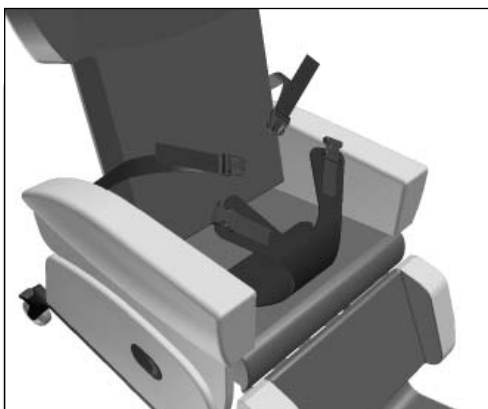

Positioning the groin harness for transfer.

If a groin harness is fitted and left loose the client may slide into sacral sitting which is a posture which will make them vulnerable to skin damage through shear & will cause discomfort and pressure in the groin area.

5j. Groin Harness

A groin harness helps to keep the user positioned correctly in the chair.

The groin harness needs to be fitted to the chair before it is used. See the notes at the end of these instructions on groin harness fitting.

Position the loose webbing straps over the arms of the chair and transfer the client onto the chair so that they are sitting on the groin harness.

Position the ends of the groin harness with the buckles attached over the client's thighs and connect the buckles to the webbing straps.

Adjust the length of the webbing straps through the buckles so that the groin harness helps control the client's position.

Do not over-tighten the straps as this may lead to discomfort. The groin harness must not be used as a restraint.

6. Accessory Fitting

6a. Tools

In day to day use, the HydroFlex does not require tools to make changes and adjustments. However, it is necessary to use tools to fit some of the accessories to the chair. Before attempting to fit these accessories, gather together the right tools. These are;

- Two 13mm spanners.
- 4mm allen key.
- Sharp craft knife.

Do not attempt to undo nuts and bolts using pliers or other grip type tools.

The nuts used on the HydroFlex are Nyloc types. These are designed not to come loose. They must also be fastened in place with spanners. Any nuts and bolts which are only tightened 'finger tight' will soon come undone. Always use spanners and ensure any assembly is fully tightened and is free of play and rattle before use.

6b. Pelvic strap and Groin Harness fitting

Both the pelvic straps and the groin harness are held in place on two 'A' plates which bolt onto the seat depth adjustment frame. There is an 8mm hole in the triangular plates of the seat depth frame for attaching the A plates.

Fit the 'A' plates to the outside of the plates on the seat depth frame with the hole through which the webbing passes pointing down. Fit a bolt through the 'A' plates and frame and tighten them together with a Nyloc nut. Ensure the assembly is fully tightened so that the 'A' plate cannot revolve on the bolt.

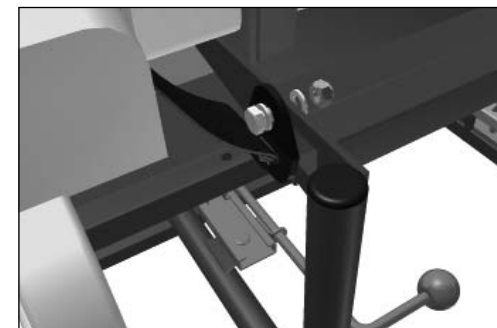

Fully tighten the Nyloc onto the bolt with two 13mm spanners, slot in 'A' plate pointing down.

6c. 4-point Pelvic Strap Front Strap Fitting.

The 4-point pelvic strap has two front straps which need to be attached to the chair.

The chair needs to be tipped onto its side to gain access to this position. This is a two person operation and a sheet or large piece of card should be put down for the chair to be tipped onto to protect the chair from damage.

The straps are fitted through the gap between the round tube and the seat depth adjustment rails, in front of the square cross bar of the seat frame.

The straps need to be looped around the tubes of the seat depth adjustment frame and threaded through the ladder lock sewn onto the ends. The straps are then positioned through the gaps on each side of the seat board and the chair sides. The straps can then be threaded through the ladder locks sewn onto each pad of the 4-point pelvic strap.

6d. Adjustable Guides

The adjustable lateral support system is based on two guides which fasten to the back of the lumbar board. The lumbar board is fitted with threaded inserts which the holding screws fasten into.

Feel through the covering material on the back of the board for two sets of eight indentations. Carefully score over these indentations with a sharp craft knife to access the threaded inserts.

Position the guides and metal guide plates over the inserts and fasten them in place with the button head screws. Use a 4mm allen key to fully tighten the screws.

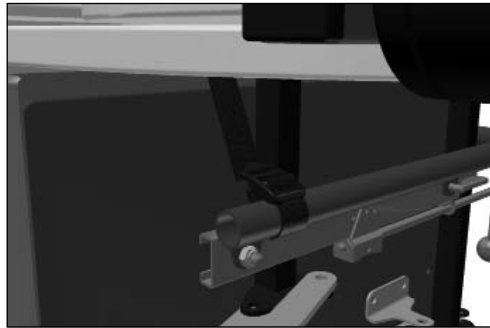

Wrap the straps around the tube and thread the ends through the ladder locks. The strap goes in front of the square cross bar.

Note: If a specific position is required for the front straps they can be screwed to the underside of the seat board. Use a chipboard screw with a maximum length of 16mm to do this.

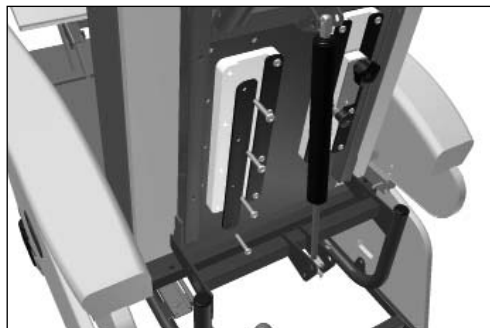

Score over the recesses in the back board and screw the guides into place.

6e. Pommel Bracket

Begin by carefully removing the seat cushion. The pommel bracket fits in a recess cut into the front edge of the seat board. The seat board is fitted with threaded inserts which the holding screws fasten into.

Feel through the covering material on the front edge of the seat board, either side of the recess, for two sets of two indentations. Carefully score over these indentations with a sharp craft knife to access the threaded inserts.

Position the bracket in the recess and fasten it in place with the supplied counter-sunk machine screws. Use a large posi-drive screw driver to fully tighten the screws.

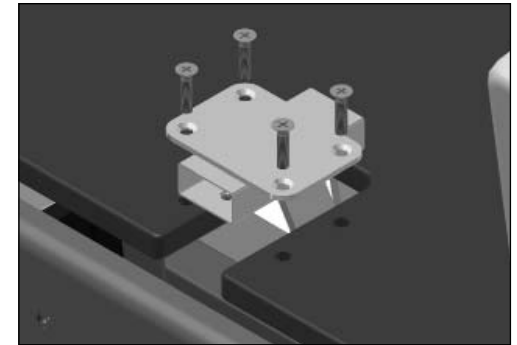

Score over the two recesses each side of the notch, position the bracket and screw in place.

6f. Anterior Knee Strap connectors

The connectors to which the anterior knee strap is fitted are held in place by velcro straps which are sandwiched between the chair arms and sides.

Carefully remove the arms to reveal the strips of hook velcro on the inside of the chair sides.

Position the connectors on the velcro strips so that the top of the buckles are level with the top of the seat cushion and they protrude forwards of the chair sides.

Carefully re-position the arms over the chair sides and connectors and ensure they are properly positioned before the chair is used.

Please note; The anterior knee strap cannot be retro-fitted to fixed cover versions of the HydroFlex.

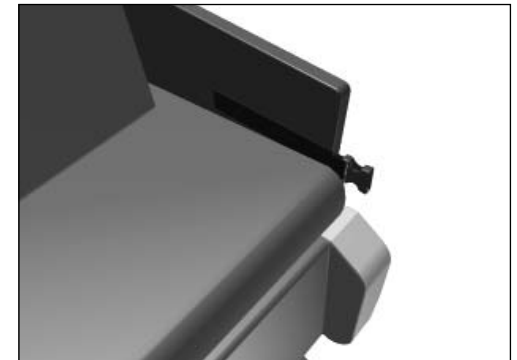

Attaching the connectors to the velcro on the chair sides.

Looking after the chair

Every time it is used, check the chair over for signs of damage or excessive wear. If the chair shows signs of excessive wear, damage or incorrect performance, please take it out of service immediately and contact CareFlex .

If the client is experiencing severe discomfort, do not use the chair. Take it out of service immediately and contact CareFlex or your local CareFlex Distributor.

The chair is upholstered in high quality materials which are waterproof and fire retardant. However, do not store or use the chair in damp or wet areas. Similarly, do not position the chair near or against sources of direct heat or naked flames. Covering materials may fade or degrade if subjected to excessive heat or sunlight. Refer to the CareFlex fabric guide for upholstery cleaning details.

Wipe up spills and contamination as soon as they are noticed. Stains and soiling can lead to staining and more severe infection control issues if not addressed immediately. Do not attempt to carry out any structural maintenance or adjustment of the chair or its accessories without consulting CareFlex.

For motorised chairs, regularly charge the batteries as per the earlier instructions.

For cleaning and decontamination procedures, refer to the appropriate section of the Fabric and Cleaning Guide supplied with the chair. Careflex use a range of covering materials, each with particular characteristics and specific cleaning guidelines. If you are unsure of the chair's covering material, contact CareFlex with the serial number for the chair which will allow CareFlex to trace the specification of the chair.

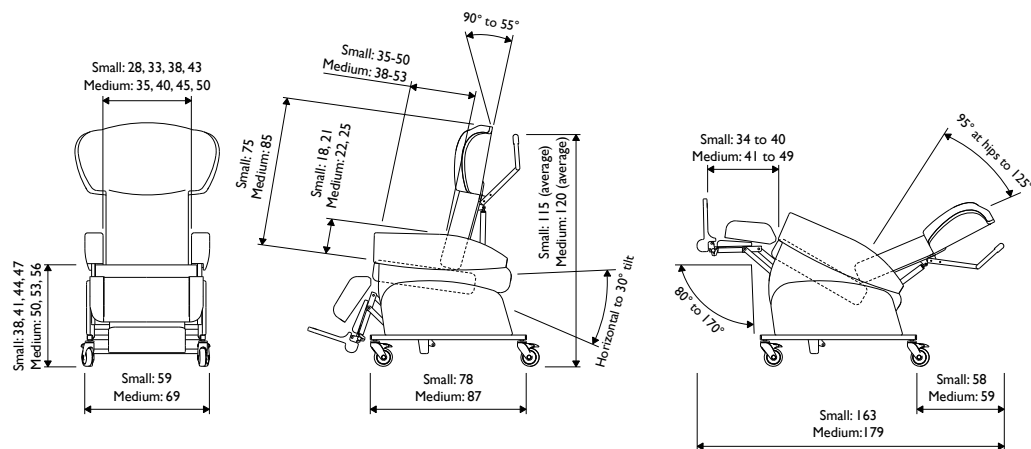

Weights	SMALL HYDROFLEX	MEDIUM HYDROFLEX
Max User Weight	100kg	150kg
Product Weight	70kg	75kg

Important Safety Information

- Please take the time to familiarise yourself with all the aspects of the chair and its functions before using the chair.
- Do not 'ride' on the push handles or subject them to excessive loads.
- Do not sit on the legrest or subject it to excessive loads.
- Do not attempt to stand on the footplate.
- Do not tip the chair backwards to ascend steps or overcome thresholds, especially if a client is sat in the chair.
- Always ensure that the client's feet do not drag on the ground when the chair is moved by elevating the legrest to lift their feet off the floor.
- Always ensure that there are no obstructions under the chair and that there is plenty of space around the chair before using the back angle recline facility.
- Always apply at least two brakes when the client is transferred to or from the chair.
- Always try to avoid storing or using the chair in areas where it may obstruct exits or passageways.
- The HydroFlex must never be used in motor vehicles for client transportation.
- Do not charge the chair's batteries when a client is sat in the chair (Pro-Control and Motorised versions).
- Do not move the chair if the charging lead is connected between the chair and mains power supply.

