



Pelvic Belts & Chest Harnesses for HydroForm[®], HydroCare[™], HydroTilt[®], and HydroFlex[®]

UI

These are the user instructions for the CareFlex range of Pelvic Belts and Chest Harnesses for the HydroForm, HydroCare, HydroTilt and HydroFlex chairs.

Please read them carefully before setting up and using the chair and keep them in a safe place for future reference.

These instructions include details of the performance of the belts and harnesses. If they should start behaving outside of their intended performance, show signs of damage or excessive wear, or otherwise feel unsuitable, please take them out of service and contact CareFlex or your CareFlex Distributor immediately.

CareFlex pelvic belts and harnesses are designed to be used as positioning aids to help the client maintain a good sitting posture whilst reducing the risk of soft tissue damage through the effects of shear which can occur if the client has an unstable posture.

WARNING

The use of pelvic belts and harnesses must be thoroughly risk assessed by a healthcare professional. Appropriate training in their function, adjustment and operation must be provided for all those who use them.

A level of supervision appropriate to the client's abilities must be applied at all times.

Pelvic Belt Use

Pelvic Belts are designed to stabilize the pelvis and keep the client in an upright, functional position.

All pelvic belts need to be correctly adjusted to adequately support the client without restricting breathing or causing discomfort. It is essential that a pelvic belt is not adjusted to fit loosely around the client and is not allowed to work loose over time as this will allow the client's pelvis to tilt backwards, encouraging them to slide down and forward in the chair.

CareFlex pelvic belts are intended to pull back over the hips at an angle between 45° and 60° . This angle helps to maintain a vertical pelvis by simultaneously pulling the hip joint down and back.

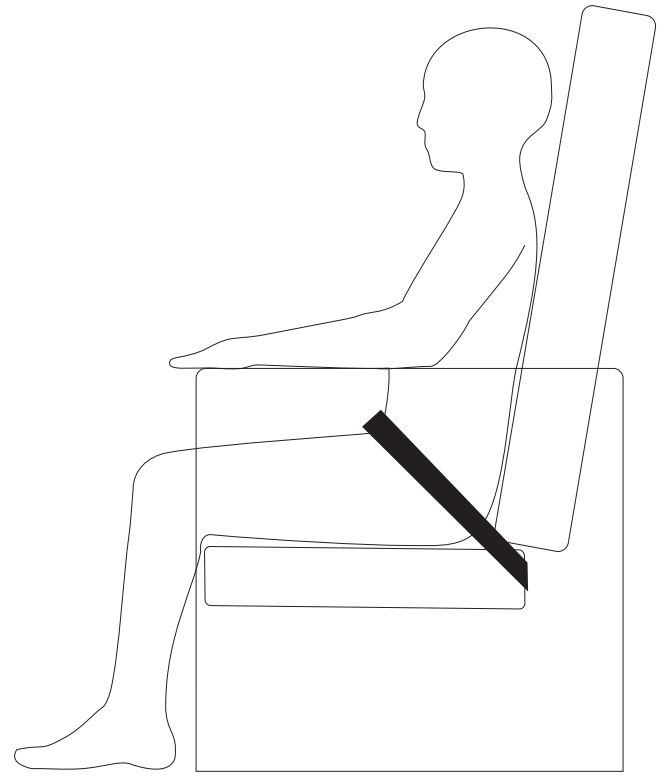

Pelvic Belt coming over the hips between 45° and 60° degrees.

4-Point Pelvic Belt Use

With a 4-Point Pelvic belt the main 40mm strap is mounted so that it sits at between 45° and 60° across the hips. This angle helps to maintain a vertical pelvis by simultaneously pulling the hip joint down and back.

The secondary straps pull down over the thighs to sit at right angles to the seat board. The secondary straps prevent the main strap riding up and provide some support to the outside of the thigh. The position of the secondary straps needs to be determined once seat depth has been established .

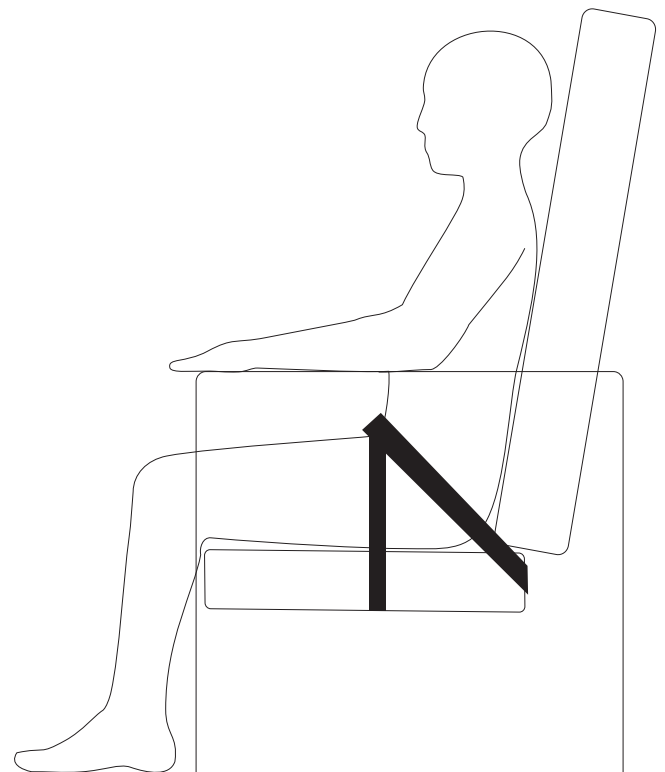

4-Point Pelvic Belt with main strap coming over the hips between 45 and 60 degrees. Secondary strap at right-angles to seat board.

Pelvic Belt

The Pelvic Belt is a simple strap made from 50mm webbing with a double adjustable buckle. It is intended for use as a safety strap when portering a client in a chair. As it is not padded, it will not be particularly comfortable as a long-term positioning aid.

Adjust the webbing through the buckle so that there is approximately 15cm of loose webbing each side. Set the main length of the belt through the mounting plates which attach it to the chair. The belt should be sufficiently tight to support and control the pelvis without being painful.

In day to day use, tension can be applied by pulling the D rings to pull the webbing through the buckle.



Pelvic Belt with double adjustable buckle.

Padded Pelvic Belt

The Padded Pelvic Belt is 'rear pull', so that day to day adjustments are made by pulling D-rings on the webbing straps which adjust in length through ladder lock buckles on the ends of the comfort pads. The main adjustment is set at the mounting points. The comfort pads are made from neoprene.

To set the belt up, Pull the D rings towards the centre buckle. Set the main length of the belt through the mounting plates which attach it to the chair. The belt should be sufficiently tight to support and control the pelvis without being painful.

In day to day use, tension can be applied by pulling the D rings forward. This will shorten the length of the belt through the ladder lock buckles, pulling the pads in towards the client.

If additional tension is required once the D rings have been pulled as far forward as possible, re-adjust the length of the belt through the mounting plates which attach the belt to the chair.



Padded Pelvic Belt with rear pull adjustment. Pulling the D-rings tensions the strap through the ladder locks.

4-point Padded Pelvic Belt

The 4-Point Padded Pelvic belt has centre pull adjustment. The main 40mm strap is mounted so that it sits at between 45° and 60° across the hips. The secondary straps pull down over the thighs to sit at right angles to the seat board. The secondary straps prevent the main belt riding up and provide some support to the outside of the thigh. The comfort pads are made from neoprene.

The secondary front straps can only be anchored once seat depth has been set up for the client. The secondary straps come down from the main pad and over the sides of the clients thighs so that they sit at right angles to the seat board. The anchor points for the secondary straps depend, therefore, on the thickness of the client's trunk and the seat depth of the chair. If seat depth is adjusted, the position of the secondary straps will need to be re-adjusted to suit.

Adjust the main webbing strap through the buckle so that there is approximately 15cm of loose webbing each side of the buckle. Set the main length of the belt through the mounting plates which attach it to the chair. The belt should be sufficiently tight to support and control the pelvis without being painful.

In day to day use, tension can be applied by pulling the D rings to pull the webbing through the buckle.

With the main strap correctly adjusted for tension and position, pull the secondary straps over the sides of the clients' thighs and down towards the seat board. The secondary straps should be at right angles to the sides of the seat board.

Mark the position of the straps and attach the fixlock buckles to the underside of the seat board accordingly. Feed the secondary straps through the fixlock buckles, pull them to the required tension so that the belt cannot ride upwards against the client and close the fixlock buckles to anchor the secondary straps in place.



4-Point Padded Pelvic Belt with double adjustable buckle and secondary front straps.

NOTE: As positioning aids, these devices are not suitable for use with chairs with waterfall backs as the softness of the back support will not give sufficient support to control the pelvis when the strap or harness is adequately tensioned.

Dynamic Chest Harness

The Dynamic Chest Harness is made from neoprene with soft edge binding which allows the harness to stretch in response to movement. This provides comfort and support whilst not restricting active positioning. The main body of the harness should be positioned so that the bottom edge is level with the lower edge of the rib cage. Four straps attach the body of the harness to the chair. The lower straps have multi-direction buckles which swivel to follow the direction of pull to the mounting point to avoid twisting and provide comfort. The Dynamic Chest Harness is designed to be used in conjunction with a pelvic belt.



Dynamic Chest Harness

Dynamic Sternum Harness

The Dynamic Sternum Harness has the same features as the Dynamic Chest Harness but has a more incised profile for greater comfort across the chest.



Dynamic Sternum Harness

Harness Position

Harnesses need to be positioned high up on the chest to act against the rib cage. Ensure the harness clears any abdominal implants.

Position the harness so that the bottom edge lines up with the bottom edge of the client's rib cage and the top sections of the harness pad sit over the collar bones. This will ensure that the webbing straps do not rub.

Day to Day Use

In day to day use when transferring a client to or from the chair, undo the shoulder straps and one of the bottom straps. The harness can remain attached to the chair with one of the lower buckles.

Regularly check and adjust the tension in the shoulder straps by pulling the folded over end of the webbing strap through the buckle.

Adjust the bottom straps at their mounting point.

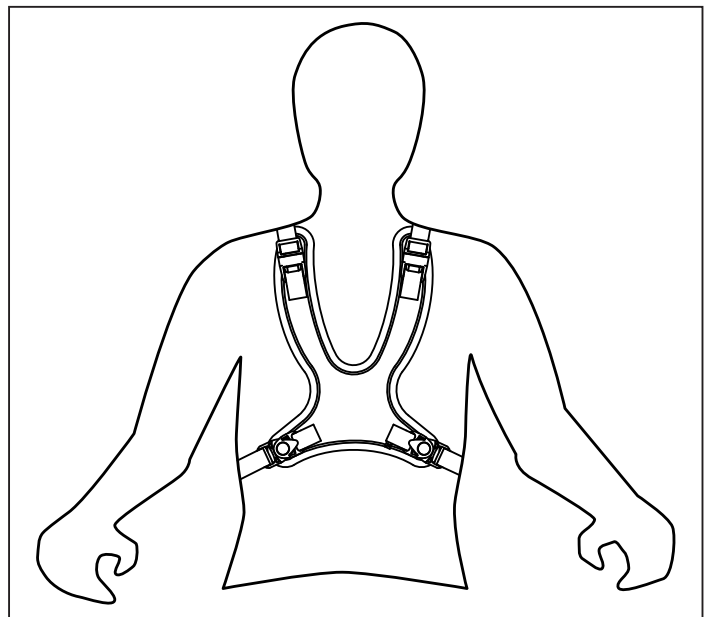

Position the harness with the lower edge level with bottom edge of the rib cage.

NOTE: There is a separate Instruction Sheet for fitting Dynamic Chest Harness and Dynamic Sternum Harnesses to HydroForms and pre-2011 HydroFlex chairs. These require a fixing harness to be attached to the chair.

Triple Bar Mounting Plates

The wide straps of the pelvic belts are mounted and adjusted through triple-bar mounting plates.

The straps need to be threaded correctly to ensure they retain the tension and set-up of the belt.

The loose end of the webbing is fed up through the first slot, down through the second and back up through the third. To hold the tension on the belt the loose end is then fed back down through the first slot so that the loose end sits flat on top of the strap going to the main body of the belt.

To adjust strap length, pull up a loop of webbing on the top of the mounting plate and feed the lower loops through the slots. Pull the top loose end of the webbing to pull the top loop down and tension the belt.

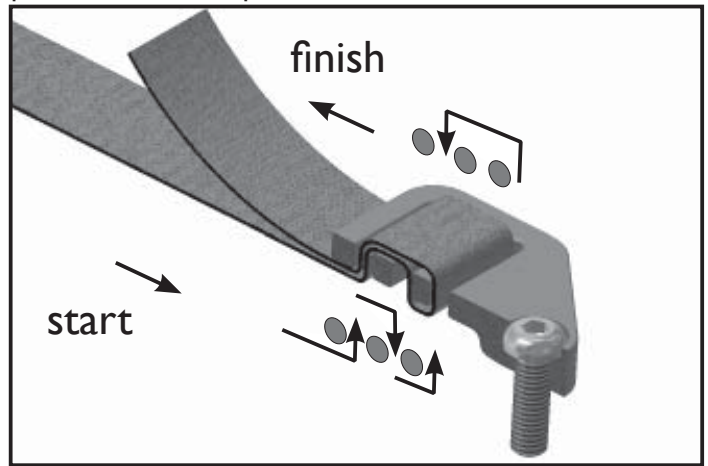

Sequence for feeding webbing straps through triple bar mounting plates.

Sizes

Pelvic Belt
Medium & Large

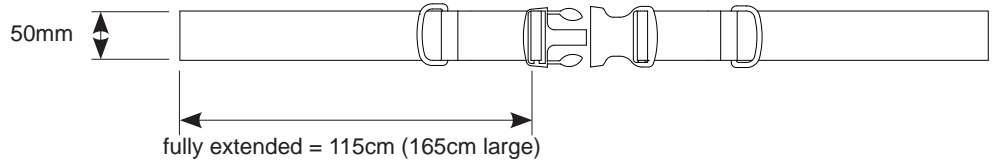

Padded Pelvic Belt
Medium & Large

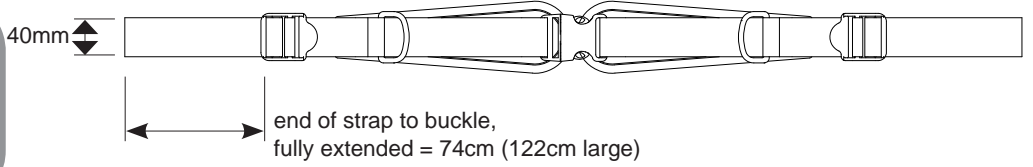

4-Point Padded Pelvic Belt
Medium & Large

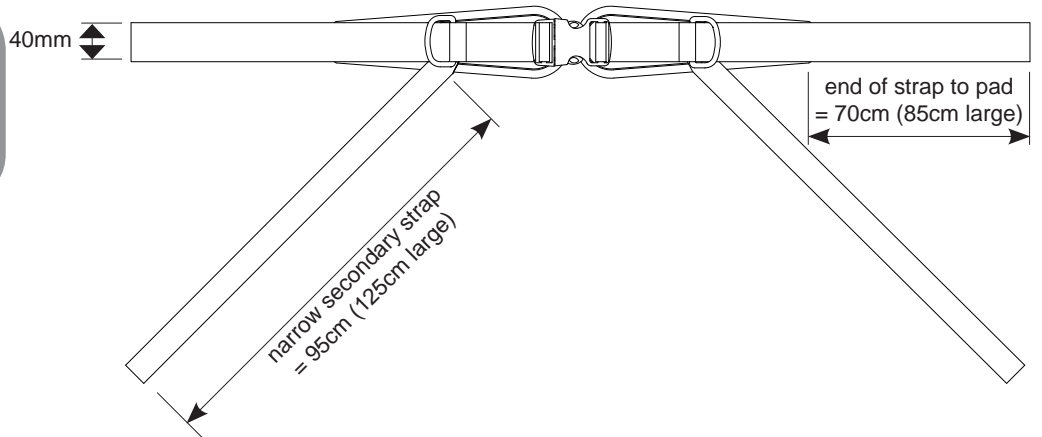

Dynamic Chest Harness
Small, Medium and Large

Dynamic Sternum Harness
Medium & Large

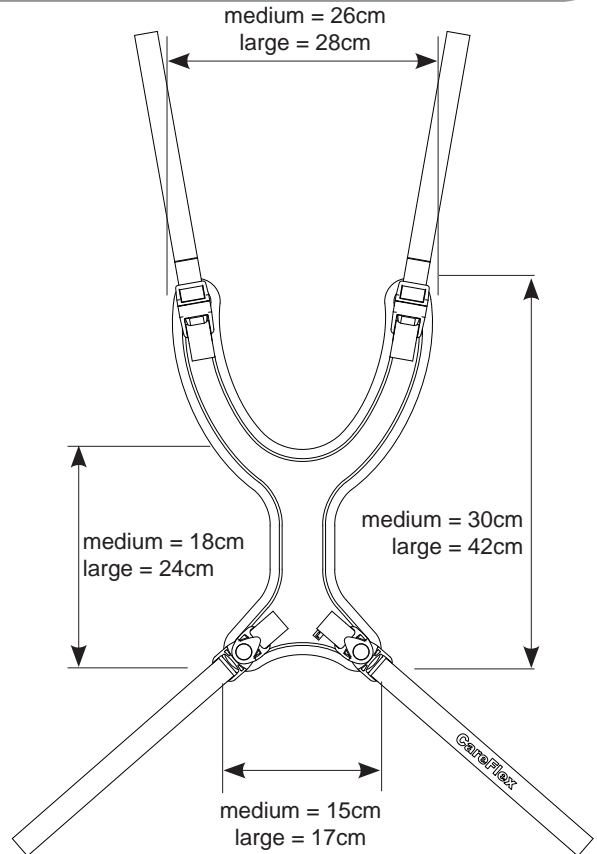
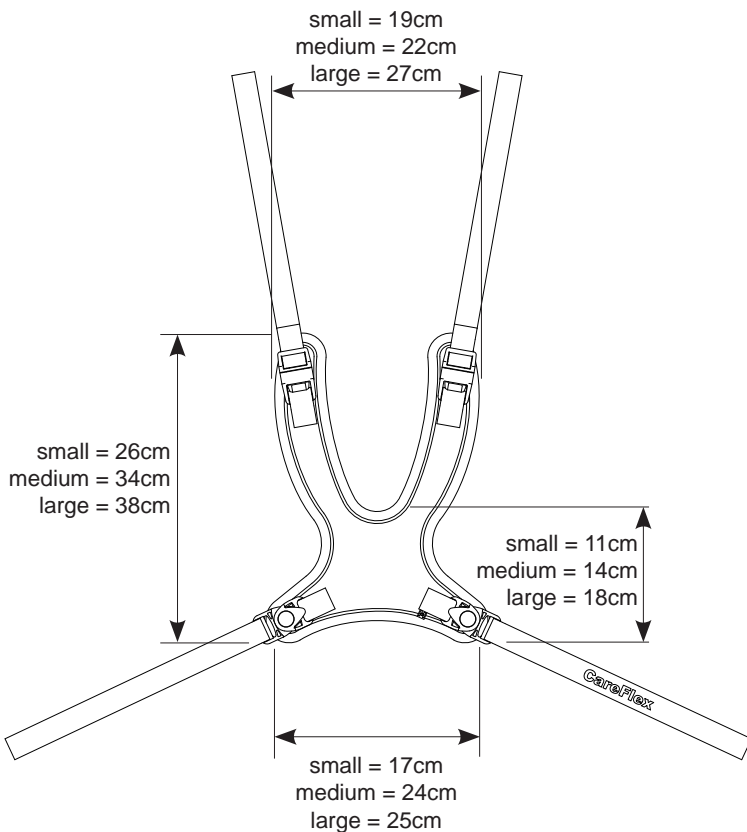

HF 1. HydroForm

HF 1a. Pelvic Belt & Padded Pelvic Belt Fitting

Fixing Kit I is required to fit the Pelvic Belt and Padded Pelvic Belt to the HydroForm.

You will need two 13mm spanners to fit the fixing kit.

The fixing kit triple bar mounting plates are fitted onto the Back Angle Recline (BAR) pivot bolts of the HydroForm chair.

Begin by lifting up the bottom inner edge of the arms. Carefully separate the Velcro closures which hold the inner arms in place and lift the inner arms up as far as possible to get access to the BAR pivot bolts.

Standing at the back of the chair, undo the lower section of the back cover so that the lower flap covering the back boards hangs loose.

Carefully pull the cover off the lower corners of the back to reveal the BAR pivot bolts where the back frame is mounted onto the seat depth frame.

Working one side at a time, undo the bolts using 13mm spanners. Pull each bolt out and fit the triple bar mounting plate in position so that the plates angle out towards the arms. Fasten the bolts back in place with the nyloc nuts using spanners.

Feed the loose ends of the belt through the triple bar mounting plates as described on page 7. Adjust the belt to the desired length so that only a small amount of adjustment is left in the strap for day-to-day tensioning.

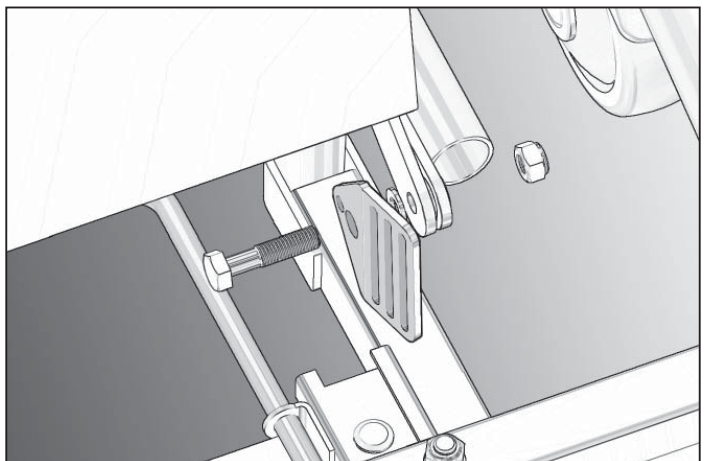

Fitting the plate onto the HydroForm BAR pivot bolts.

HF 1b. Fitting a 4-Point Padded Pelvic Belt to a HydroForm

Fixing Kit 10 is required to fit the 4-Point Padded Pelvic Belt to the HydroForm.

You will need two 13mm spanners and a cross-head screwdriver to fit the fixing kit. Use masking tape as a means of marking the position of the front straps. It will be necessary to tip the chair onto its side to attach the front strap fixings. This is a two person operation and the upholstery of the chair must be protected when the chair is lying on its side.

The fixing kit triple bar mounting plates are fitted onto the Back Angle Recline (BAR) pivot bolts of the HydroForm chair as per the instructions for the Pelvic and Padded Pelvic Belt.

Set seat depth to suit the client as per the User Instructions for the chair. Fit the pelvic belt around the client and tension the belt as per the earlier instructions.

Pull the front straps across the client's thighs and down towards the seat board. Use masking tape to mark the position of the straps relative to the sides of the seat board/cushion.

Transfer the client out of the chair and tip the chair onto its side. Feed the front straps through the gap between the seat board (beneath the cushion) and the seat frame. Line the straps up against the masking tape markers to establish the position of the fixlock buckles.

Position the fixlock buckles and screw them in place with the small self-tapping screws provided. Once the buckles are securely screwed in place, feed the loose ends of the front straps through the buckles.

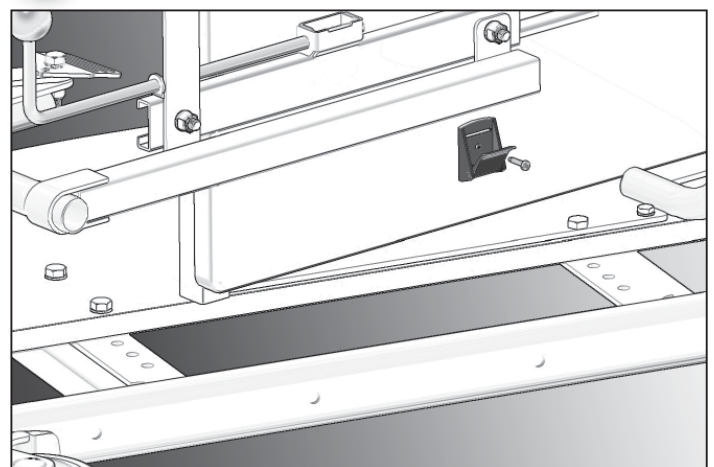
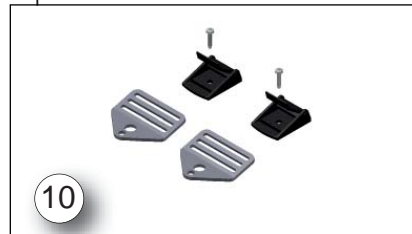

Screw fixlocks in place for the front straps on the underside of the seat board.

Lift the chair back onto its wheels and transfer the client back into the chair.

Fasten the belt around the client and adjust to the correct tension.

From the back of the chair, pull the front straps through the fixlock buckles so that they are sufficiently tensioned to stop the main belt riding upwards.

Close the fixlock buckles to clamp the front straps in place. There should be no need to adjust the front straps in day to day use but their tension must be regularly checked to accommodate growth or if seat depth is adjusted.

HC 2. HydroCare

HC 2a. Pelvic Belt & Padded Pelvic Belt Fitting

Pelvic belts are intended to be used as positioning aids to help keep the client stable in the chair with a vertical pelvic posture, reducing the tendency to sacral sit and limiting soft tissue damage through the effect of shear.

The pelvic belt is attached to the square tube of the seat depth adjustment frame. The mounting points for the pelvic belt also control pelvic belt length adjustment.

Due to the nature of pelvic belt use, and in order to prevent misuse, the length of the pelvic belt can be adjusted and set by the healthcare professional to ensure a regular and constant tension on the belt and prevent it being adjusted so that it sits loose around the client, which is potentially harmful.

Adjust the pelvic belt so that there is 10 to 15cm of loose webbing on each side of the buckle and join the two halves of the side release buckle together.

Fit the ends of the belt between the chair back and arms and position them close to the square bar running across the back of the chair.

Tri-glide buckles need to be fitted on the straps so that they sit behind the square bar. Use kit 2 (50mm) for the Pelvic Belt and kit 6 (40mm) for the Padded and 4-Point Padded Pelvic Belts. Loop the webbing over the bar and feed it back through the buckle.

Adjust the length of the belt as desired. Once at the correct length, fold the loose end of the webbing back over the buckle and feed it under the last bar of the tri-glide. This will ensure that the belt does not slowly loosen over time.

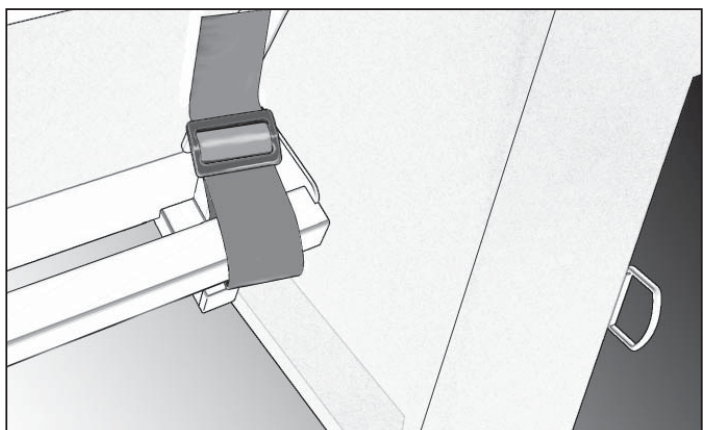
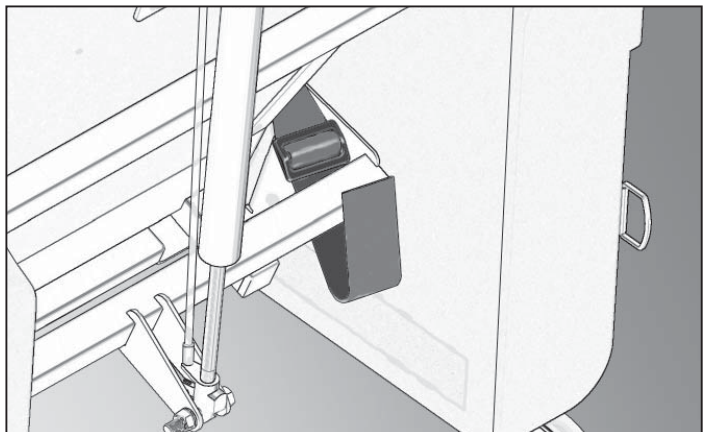
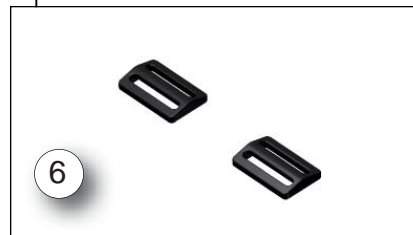

2e. Fitting 4-Point Padded Pelvic Belt to a HydroCare

A 4-Point Pelvic Belt cannot be used with a waterfall back as the softness of the back will not give sufficient support to control the pelvis when the strap is tensioned.

Fixing Kit 11 is required to fit the 4-Point Padded Pelvic Belt to the HydroCare. You will need a cross-head screwdriver to fit the fixing kit. Use masking tape as a means of marking the position of the front straps. It will be necessary to tip the chair onto its side to attach the front strap fixings. This is a two person operation and the upholstery of the chair must be protected when the chair is lying on its side.

Fit the main 40mm wide straps as per the instructions for the HydroCare Pelvic and Padded Pelvic Belt.

Set seat depth to suit the client as per the User Instructions for the chair. Fit the pelvic belt around the client and tension the belt as per the earlier instructions.

Pull the front straps across the client's thighs and down towards the seat board. Use masking tape to mark the position of the straps relative to the sides of the seat board/cushion.

Transfer the client out of the chair and put the chair on its side. Feed the front straps through the gap between the seat board (beneath the cushion) and the arms. Line the straps up against the masking tape markers to establish the position of the Fixlock buckles.

Position the fixlock buckles and screw them in place with the small self-tapping screws provided. Once the buckles are securely screwed in place, feed the loose ends of the front straps through the buckles.

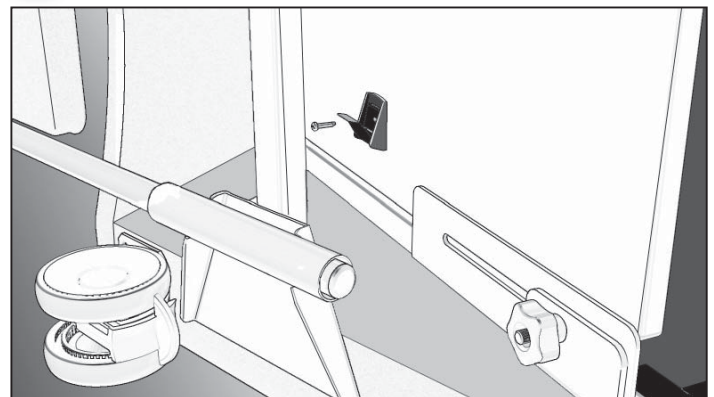
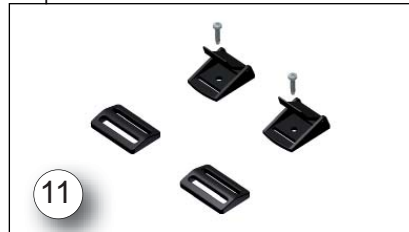

Screw fixlocks in place for the front straps on the underside of the seat board.

Lift the chair back onto its wheels and transfer the client back into the chair.

Fasten the belt around the client adjust to the correct tension.

From the back of the chair, pull the front straps through the fixlock buckles so that they are sufficiently tensioned to stop the main belt riding upwards.

Close the fixlock buckles to clamp the front straps in place. There is no need to adjust the front straps in day to day use but their tension must be regularly checked to accommodate growth or if seat depth is adjusted.

HT 3. HydroTilt

HT 3a. HydroTilt pre-2012

Fixing Kit 3 is required to fit the Pelvic Belt to HydroTilts made before 2012.

You will need a 17mm spanner to fit the fixing kit.

HT 3b. HydroTilt 2012 onward

Fixing Kit 4 is required to fit the Pelvic Belt to HydroTilts made from 2012 onwards.

You will need a 10mm spanner to fit the fixing kit.

HT 3c. Fitting a Pelvic Belt to a HydroTilt

The fixing kit triple bar mounting plates are fitted to the mounting holes in the sides of the chair below the bottom back edge of the seat board.

At the back of the chair, locate the holes in the sides of the chair. If they are protected with a dust cap, flick the dust cap out to reveal the threaded insert in the timber.

Position the plates over the holes and using the appropriate size hexagonal head screw, fasten the plates in place so that they point to the front of the chair and angle out to the middle of the chair.

Use the appropriate size spanner to ensure the plates are fully tightened in place and thread the loose end of the webbing through the plates as per the details on page 5. Adjust the belt to the desired length so that only a small amount of adjustment is left in the strap for day-to-day tensioning.

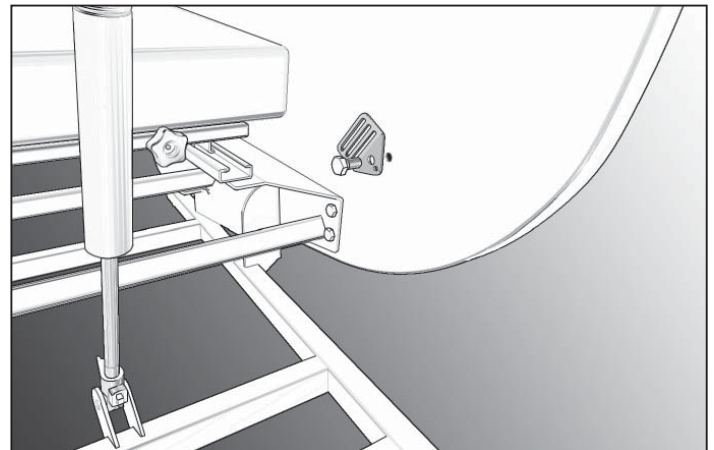
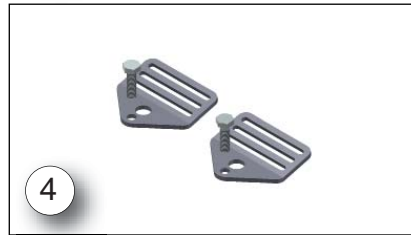
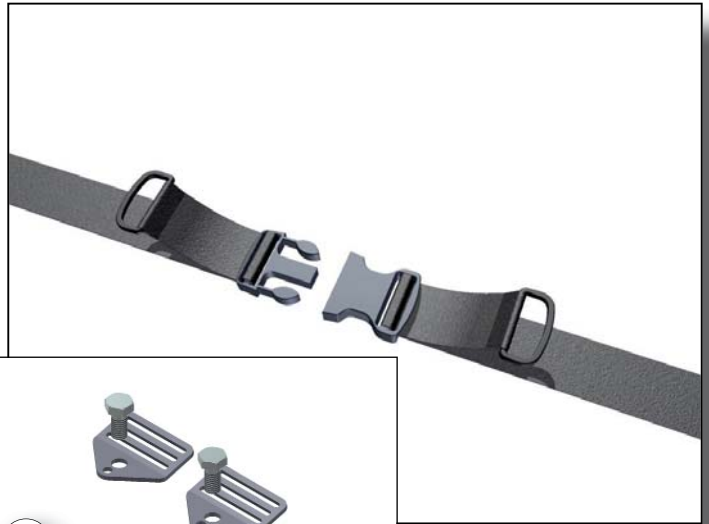

Steel triple slot mounting plate for Pelvic Belt.

A large M10 screw is fitted through the large round hole in the plate and into the mounting hole on HydroTilt chairs pre-2012.

A thinner M6 screw is fitted into the smaller round hole in the plate and into the mounting hole on HydroTilts from 2012 onwards.

HT 3d. Padded Pelvic Belt**HT 3e. HydroTilt pre-2012**

Fixing Kit 7 is required to fit the Pelvic Belt to HydroTilts made before 2012.

You will need a 13mm spanner and 4mm allen key to fit the fixing kit.

HT 3f. HydroTilt 2012 onward

Fixing Kit 8 is required to fit the Pelvic Belt to HydroTilts made from 2012 onwards.

You will need a 4mm allen key to fit the fixing kit.

HT 3g. Fitting a Padded Pelvic Belt to a HydroTilt

The fixing kit plastic triple bar mounting plates are fitted to the mounting holes in the sides of the chair below the bottom back edge of the seat board.

At the back of the chair, locate the holes in the sides of the chair. If they are protected with a dust cap, flick the dust cap out to reveal the threaded insert in the timber.

For chair built before 2012, a reducer needs to be fitted into the threaded hole first. Turn these into the threaded holes and ensure they are fully tightened in place with a 13mm spanner.

Position the plates over the holes in the chair sides or the ends of the reducers and fasten the plates in place so that they point to the front of the chair and angle out to the middle of the chair. Use the button head screws of the fixing kit and 4mm allen key to do this.

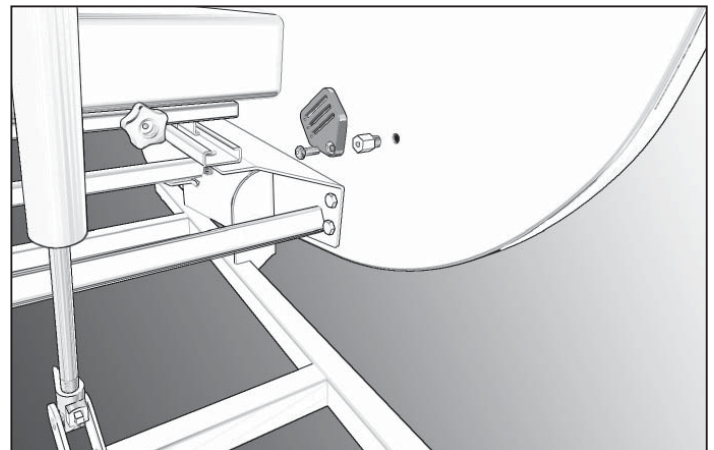
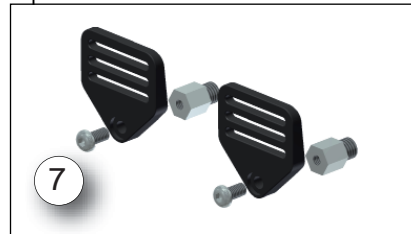

Plastic triple slot mounting plate for Padded Pelvic Belt. Mount shown for pre-2012 HydroTilt, reducer fitted into mounting hole and plate mounted onto reducer. The reducer is not required for chairs after 2012.

Thread the loose end of the webbing through the plates as per the details on page 5. Adjust the belt to the desired length so that only a small amount of adjustment is left in the strap for day-to-day tensioning.

HT 3h. 4-Point Padded Pelvic Belt

HT 3i. HydroTilt pre-2012

Fixing Kit 12 is required to fit the 4-Point Padded Pelvic Belt to HydroTilts made before 2012.

You will need a 13mm spanner, 4mm allen key and cross head screwdriver to fit the fixing kit.

HT 3j. HydroTilt 2012 onward

Fixing Kit 13 is required to fit the 4-Point Padded Pelvic Belt to HydroTilts made from 2012 onwards.

You will need a 4mm allen key and cross head screwdriver to fit the fixing kit.

HT 3k. Fitting a 4-Point Padded Pelvic Belt to a HydroTilt

Use masking tape as a means of marking the position of the front straps. It will be necessary to tip the chair onto its side to attach the front strap fixings. This is a two person operation and the upholstery of the chair must be protected when the chair is lying on its side.

Fit the main strap of the belt as per the instructions for Padded Pelvic Belts.

Set seat depth to suit the client as per the User Instructions for the chair. Fit the pelvic belt around the client and tension the belt as per the earlier instructions.

Pull the front straps across the client's thighs and down towards the seat board. Use masking tape to mark the position of the straps relative to the sides of the seat board/cushion.



Transfer the client out of the chair and tip the chair onto its side. Feed the front straps through the gap between the seat board (beneath the cushion) and the sides of the chair. Line the straps up against the masking tape markers to establish the position of the fixlock buckles.

Position the fixlock buckles and screw them in place with the small self-tapping screws provided. Once the buckles are securely screwed in place, feed the loose ends of the front straps through the buckles.

Lift the chair back onto its wheels and transfer the client back into the chair.

Fasten the belt around the client and adjust to the correct tension.

From the back of the chair, pull the front straps through the fixlock buckles so that they are sufficiently tensioned to stop the main belt riding upwards.

Close the fixlock buckles to clamp the front straps in place. There should be no need to adjust the front straps in day to day use but their tension must be regularly checked to accommodate growth or if seat depth is adjusted.

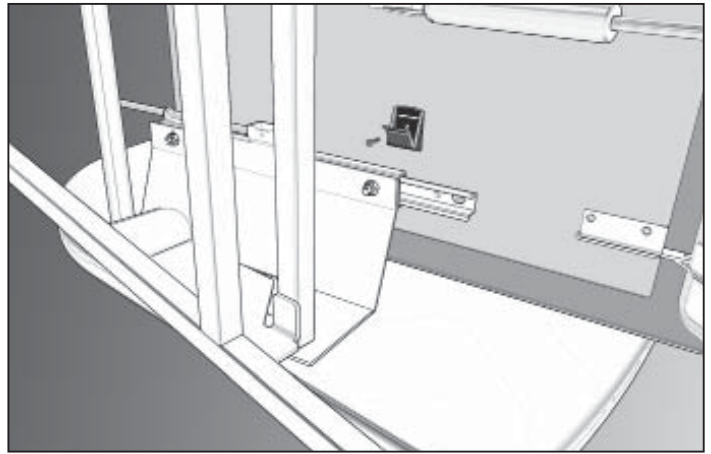

Screw fixlocks in place for the front straps on the underside of the seat board.

HT 3f. Dynamic Chest and Sternum Harnesses

Fixing Kit 16 is required to fit the Dynamic Chest or Dynamic Sternum harnesses to all HydroTilts.

You will need a 17mm spanner and cross-head screw driver to fit the fixing kit.



HT 3g. Fitting Dynamic Chest & Sternum Harnesses to a HydroTilt

A positioning strap needs to be fitted to the HydroTilt over the back cushion near the height of the client's shoulders.

Pull the back cushion forward to give access to the inside of the side panels. Feel for two sets of indentations in the Velcro strip along the inside of the side panel on the underneath the wing.

Position the steel brackets over the indentations closest to the height of the client's shoulders and use a 17mm spanner to fit the brackets in place with the chunky hexagonal head screws provided.

Re-fit the back cushion after carefully fitting it beneath the positioning strap.

Pull the positioning strap tight over the cushion by adjusting the webbing through the buckles on the strap.

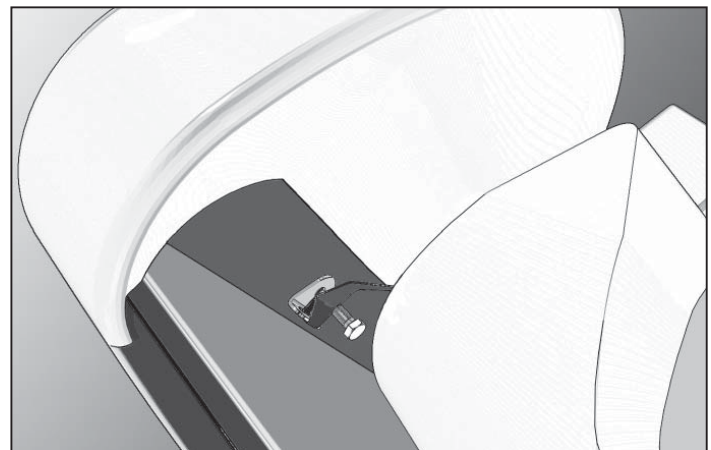

Locate the holes closest to the height of the client's shoulders and fasten the brackets in place.

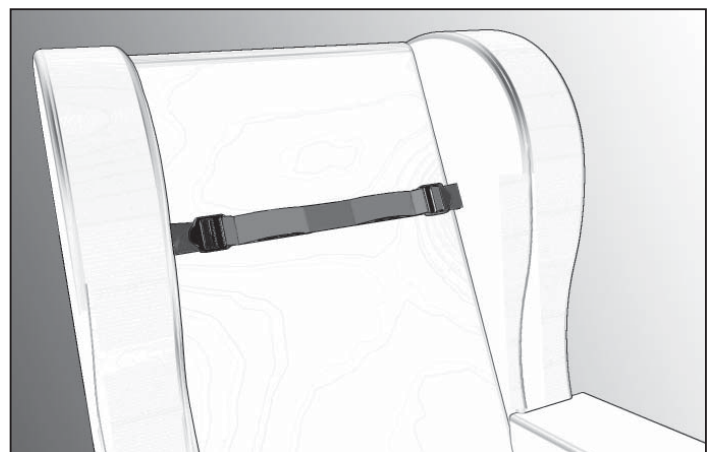

Cross strap tensioned across the front of the back cushion. Feed the top straps through the loops on the front.

Once the cross strap has been fitted the shoulder and bottom straps need to be fitted.

Feed the shoulder straps through the loops on the front of the cross strap. Fit a 25mm ladder lock buckle onto the end of the strap.

Loop the end of the strap under the push bar on the top back edge of the chair back board and feed it back through the 25mm ladder lock to hold the webbing in place. Repeat for the other shoulder strap.

The bottom straps are tensioned and held in place with fixlock buckles which need to be attached to the bottom edge of the back board, one on either side.

Position the buckle so that it points down towards the bottom edge of the board. The fixlock should be positioned approximately 1cm from the bottom edge of the back board and 7cm in from the side of the chair.

Using a cross-head screwdriver and the screws provided, screw the fixlock buckles to the back board.

Feed the bottom straps of the chest harness through the gap between the seat and back cushions and fit the ends through the fixlock buckles.

Tension the top straps by pulling the loose ends which loop through the buckles on the top of the harness.

Once the client is in the chair, tension the bottom straps by opening the fixlock buckles, pulling the ends of the straps to the required tension and closing the buckles to lock the straps in place.

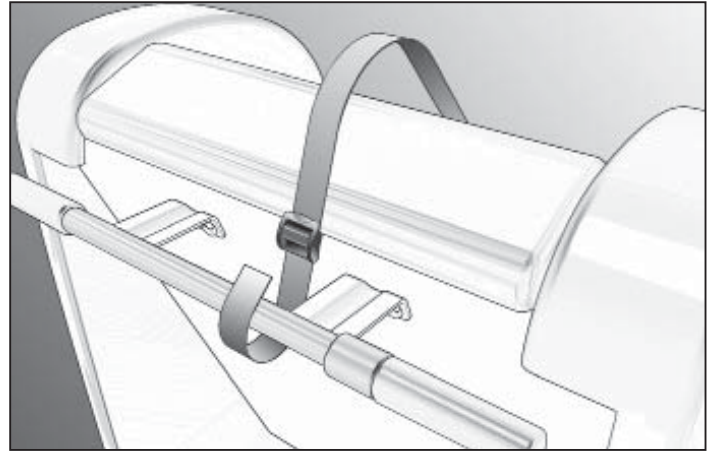

Fit the ladder locks onto the straps before wrapping the straps around the push bar and feeding the ends back through the ladder locks.

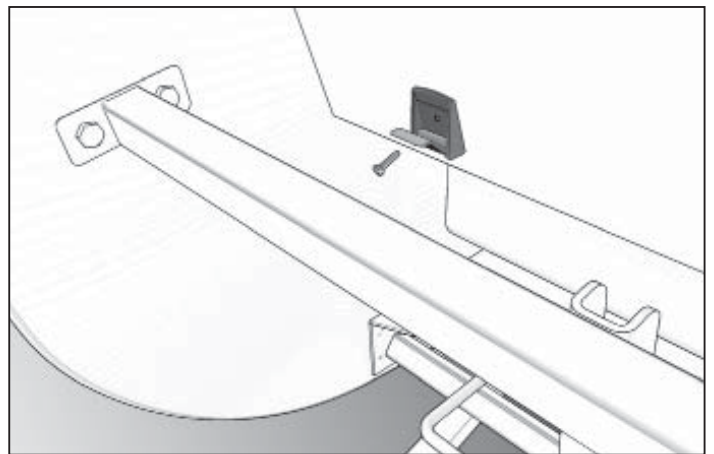

Screw fixlocks to the bottom edge of the back board and adjust the length of the bottom straps through these.

HX 4. HydroFlex

HX 4a. Pelvic belt

Fixing Kit 5 is required to fit the Pelvic Belt to a HydroFlex.

You will need two 13mm spanners to fit the fixing kit.



HX 4b. Fitting a Pelvic Belt to a HydroFlex

The fixing kit triple bar mounting plates are fitted to the mounting holes in the triangular plates behind the back angle pivot points of the seat depth adjustment frame.

At the back of the chair, locate the holes in the sides of the seat depth adjustment frame.

Position the mounting plates over the holes in the triangular plates and fasten the mounting plates in place so that they point to the front of the chair and angle out to the sides of the chair. Use two 13mm spanners to tighten the plates in place with the M8 x 20mm hexagonal head screws and M8 nyloc nuts. Fit a steel washer between the nuts, screw heads and the metalwork.

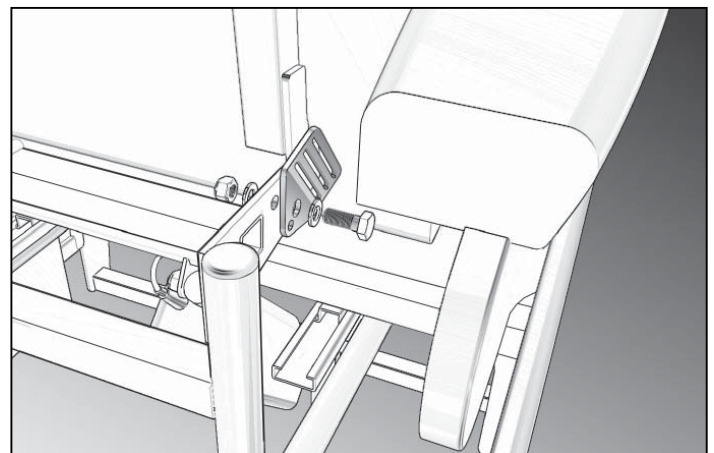

Bolt the triple bar mounting plate through the hole in the triangular plate of the seat depth adjustment frame.

HX 4c. Padded Pelvic Belt

Fixing Kit 9 is required to fit the Padded Pelvic Belt to a HydroFlex.

You will need a 10mm spanner and 4mm allen key to fit the fixing kit.

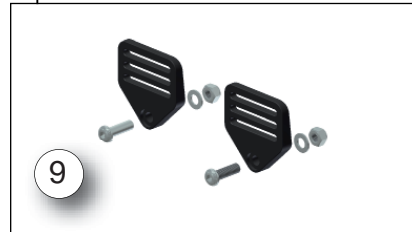

HX 4d. Fitting a Padded Pelvic Belt to a HydroFlex

The fixing kit plastic triple bar mounting plates are fitted to the mounting holes in the triangular plates behind the back angle pivot points of the seat depth adjustment frame.

At the back of the chair, locate the holes in the sides of the seat depth adjustment frame.

Position the plastic mounting plates over the holes in the triangular plates and fasten the mounting plates in place so that they point to the front of the chair. There are recesses in the plastic mounting plates for the head of the socket button head screws used to fasten the mounting plates in place. The recesses need to face outwards. Use a 10mm spanner and 4mm allen key to tighten the plates in place with the M6 x 20mm socket button head screws and M6 nyloc nuts. Fit a steel washer between the nut and metalwork.

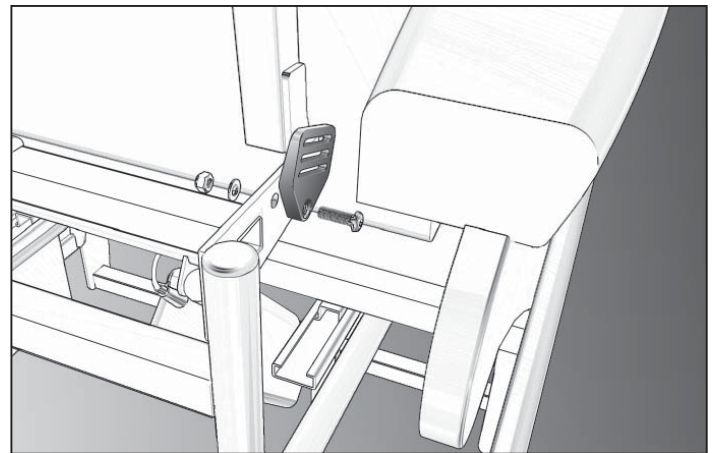

Fasten the plastic triple bar mounting plate through the hole in the triangular plate of the seat depth adjustment frame.

HX 4e. 4-Point Padded Pelvic Belt

Fixing Kit 14 is required to fit the 4-Point Padded Pelvic Belt to a HydroFlex. You will need a 10mm spanner, 4mm allen key and a cross head screwdriver to fit the fixing kit.

HX 4f. Fitting 4-Point Padded Pelvic Belt to a HydroFlex

Use masking tape as a means of marking the position of the front straps. It will be necessary to tip the chair onto its side to attach the front strap fixings. This is a two person operation and the upholstery of the chair must be protected when the chair is lying on its side.

The fixing kit triple bar mounting plates are fitted onto the seat depth frame of the chair as per the instructions for the Padded Pelvic Belt.

Set seat depth to suit the client as per the User Instructions for the chair. Fit the pelvic belt around the client and tension belt as per the earlier instructions.

Pull the front straps across the client's thighs and down towards the seat board. Use masking tape to mark the position of the straps relative to the sides of the seat board/cushion.

Transfer the client out of the chair and tip the chair onto its side. Feed the front straps through the gap between the seat board (beneath the cushion) and the seat frame. Line the straps up against the masking tape markers to establish the position of the fixlock buckles.

Position the fixlock buckles and screw them in place with the small self-tapping screws provided. Once the buckles are securely screwed in place, feed the loose ends of the front straps through the buckles.

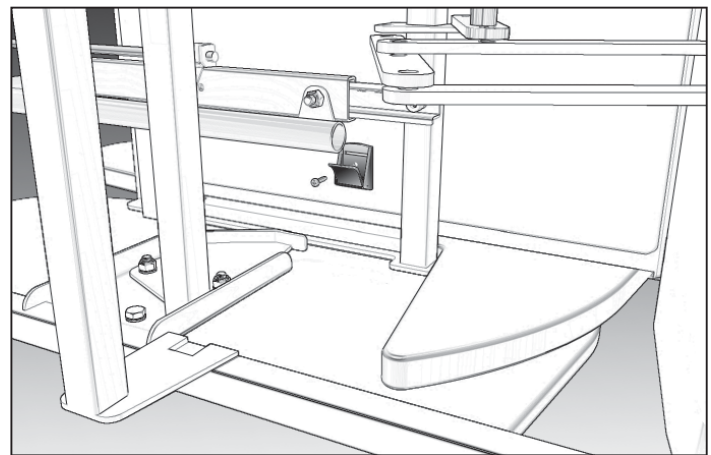

Screw the fixlocks to the underside of the seat board.

Lift the chair back onto its wheels and transfer the client back into the chair.

Fasten the belt around the client adjust to the correct tension. From the back of the chair, pull the front straps through the fixlock buckles so that they are sufficiently tensioned to stop the main belt riding upwards.

Close the fixlock buckles to clamp the front straps in place. There should be no need to adjust the front straps in day to day use but their tension must be regularly checked to accommodate growth or if seat depth is adjusted.

HX 4f. Dynamic Chest and Sternum Harnesses

Fixing Kit 15 is required to fit either a Dynamic Chest or Sternum Harness to a HydroFlex.

HX 4g. Fitting Dynamic Chest & Sternum Harnesses

The shoulder straps of the chest or sternum harness fit in the gap between the lumbar cushion and the headboard of the HydroFlex. They are anchored around the round, upright tubes of the push bar.

Fit the straps through the gap and fit ladder locks onto the loose ends. Wrap the straps around the tubes of the push handle and feed the ends back through the ladder locks to hold the straps in place.

The lower straps fit through the gap between the lumbar cushion and the seat cushion. Fit the remaining ladder lock buckles onto the loose ends of the webbing, wrap the webbing around the top square tube of the seat depth adjustment frame, each side of the back angle recline actuator/action brackets.

Re-thread the webbing back through the ladder lock to hold the webbing in place.

Once the client is sat in the chair the tension of the straps can be adjusted to suit.

The shoulder straps can be adjusted through the buckles on the top of the harness.

The lower straps need to be tensioned by adjusting through the ladder locks holding the strap in place around the top square tube of the seat depth adjustment frame.

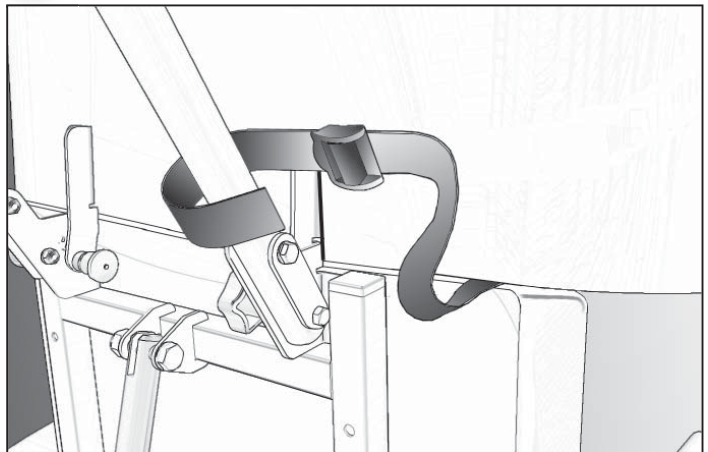

Shoulder strap through gap between lumbar and head board, wrapped around push bar tube and held in place with ladder lock.

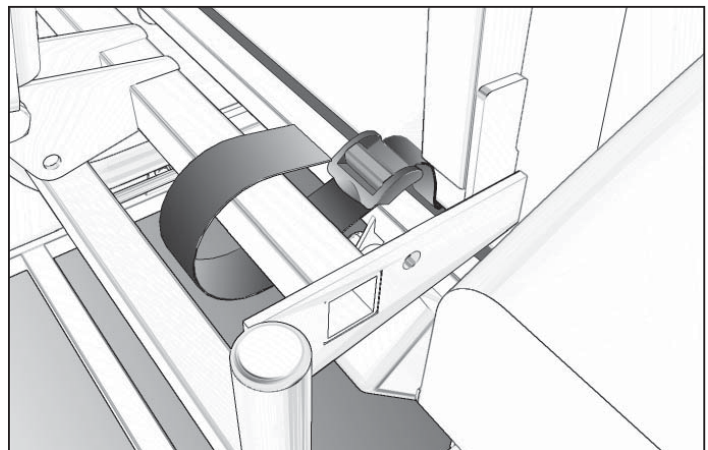

Lower strap through gap between lumbar and seat board, wrapped around top cross bar of seat depth frame and held in place with ladder lock.

Kit 1

HAR0131 triple slot mounting plate x 2



Kit 2

HAR0093 Tri-glide, 50mm x 2



Kit 3

HAR0131 triple slot mounting plate x 2
 FAS0006 M10 x 20mm hex head set screw x 2



Kit 4

HAR0131 triple slot mounting plate x 2
 FAS0007 M6 x 20mm hex head set screw x 2



Kit 5

HAR0131 triple slot mounting plate x 2
 FAS0002 M8 Nyloc x 2
 FAS0008 M8 x 20mm hex head set screw x 2
 FAS0026 M8 steel washer x 4

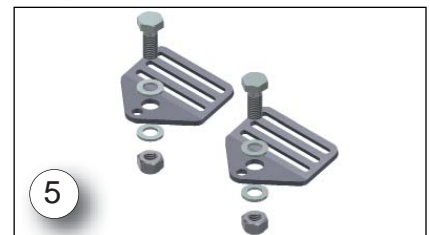

Kit 6

HAR0092 Tri-glide, 40mm x 2

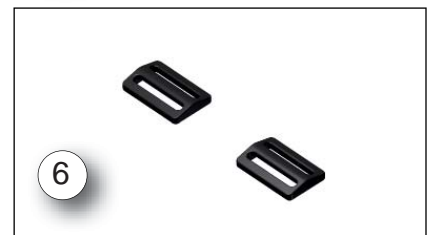

Kit 7

CFLEXMP034 plastic triple slot mounting plate x 2
 HAR0132 M10 to M6 reducer x 2
 FAS3015 M6 x 12mm socket button head x 2



Kit 8

CFLEXMP034 plastic triple slot mounting plate x 2
 FAS0017 M6 x 16mm socket button head x 2



Kit 9

CFLEXMP034 plastic triple slot mounting plate x 2
 FAS0001 M6 nyloc x 2
 FAS0048 M6 steel washer
 FAS2014 M6 x 20mm socket button head x 2

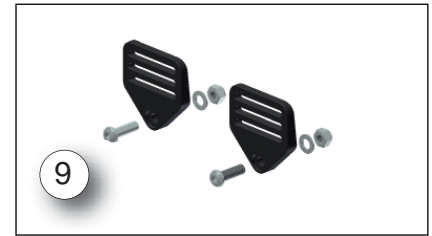
**Kit 10**

HAR0131 triple slot mounting plate x 2
 FAS4009 25mm Fixloc
 FAS0004 Screw, panhead, 6 x 5/8"

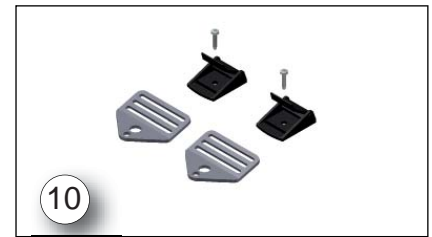
**Kit 11**

HAR0092 tri-glide, 40mm x 2
 FAS4009 25mm Fixloc
 FAS0004 Screw, panhead, 6 x 5/8"

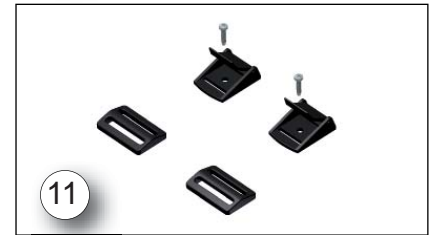
**Kit 12**

CFLEXMP034 plastic triple slot mounting plate x 2
 HAR0132 M10 to M6 reducer x 2
 FAS3015 M6 x 12mm socket button head x 2
 FAS4009 25mm Fixloc
 FAS0004 Screw, panhead, 6 x 5/8"

**Kit 13**

CFLEXMP034 plastic triple slot mounting plate x 2
 FAS0017 M6 x 16mm socket button head x 2
 FAS4009 25mm Fixloc
 FAS0004 Screw, panhead, 6 x 5/8"

**Kit 14**

CFLEXMP034 plastic triple slot mounting plate x 2
 FAS0001 M6 nyloc x 2
 FAS0048 M6 steel washer
 FAS2014 M6 x 20mm socket button head x 2
 FAS4009 25mm Fixloc
 FAS0004 Screw, panhead, 6 x 5/8"

**Kit 15**

HAR3014 25mm ladder lock x 4



Kit 16

HAR3014 25mm ladder lock x 2

FAS4009 25mm Fixloc

FAS0004 Screw, panhead, 6 x 5/8"

CFLEX-012 Secondary strap x 1

FAS0006 M10 x 20 hex head set screw x 2

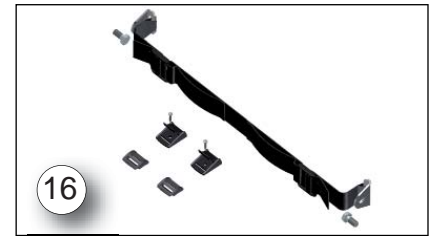

Important Safety Information

- Please take the time to familiarise yourself with all the aspects of the belt or harness and its functions before using it.
- Every time the belt or harness is used check it over for signs of damage including damaged or cracked buckles, loose seams and damaged or frayed stitching. If the belt or harness shows signs of damage, take it out of service immediately and assess whether it is safe to continue using the chair.
- The belts and harnesses are not vehicle safety devices and must not be used as such in vehicles.
- The belts and harnesses should be cleaned regularly to maintain appearance and performance. Machine wash at 60° and drip dry. Do not tumble dry, bleach, or iron.

