

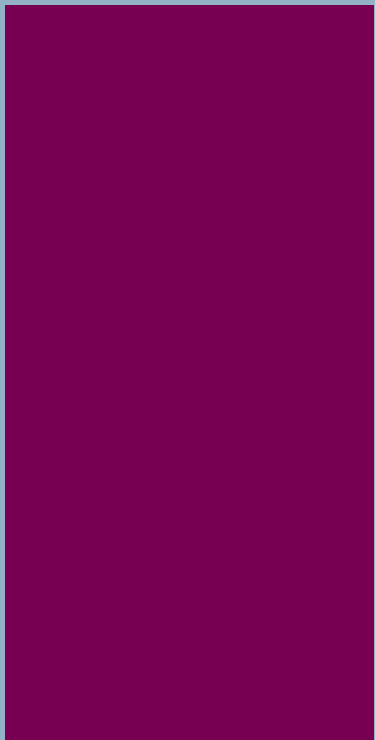

The New HydroCare®

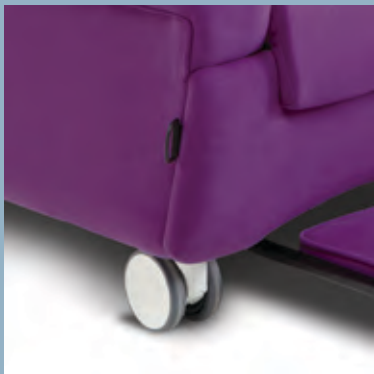

The HydroCare®
The CareFlex nursing chair



HydroCare[®]

The CareFlex nursing chair

The all new HydroCare from CareFlex is a supportive and adaptable nursing chair that incorporates a wide range of features to optimise the seating experience of its occupants.

Traditional upholstery methods have been used to give the chair clean contemporary lines and a welcoming feel.

The HydroCare has all the dynamic features you would expect from a CareFlex chair, like a large range of seat depth adjustment, back angle recline and seat angle adjustment.

The HydroCare is available in nine combinations of seat height and seat width so a good, supportive fit can be achieved for a wide range of clients. The chair also features CareFlex's WaterCell Technology[®] in the seat as standard, addressing most pressure relief needs. CareFlex have specified as standard high quality, twin wheel castors to make the chair easy to push and a sliding footplate to support feet whilst portering.

A range of covering materials is available, all of which are easy to clean to keep the chair free of contamination and looking good. So, from private front room to nursing home day room, the HydroCare should be the first choice for ambulant clients who need high levels of comfort, support and security.



The HydroCare[®] with sliding footplate

HydroCare[®]

The CareFlex nursing chair

New



Flat back



Contoured back



Waterfall back

Select the best back for comfort and support

Flat and Contoured Back

The Flat and Contoured backs are based on foam structured cushions. Both have a mid-lumbar change of angle to fully support the back and encourage a comfortable and relaxed sitting posture when the chair is semi-reclined. The foam used is a 'Reflex' grade for comfort and durability, they have a fibre face for initial softness.

The Contoured back has additional lateral support in the lumbar area through additional foam shapes which provide basic lateral support.

Waterfall Back

The three part waterfall back consists of fibre filled pillows which overlap down the back of the chair to provide a very soft, conforming back support. The top pillow provides support to the head and shoulders with a curved bottom edge to mould naturally to the client's back. The smaller cushions in the lumbar area provide support for the lower back.

The cushions can be removed individually and attach to the same Velcro strips on the back board as the foam structured cushions.



WaterCell
TECHNOLOGY

Client Groups

- Sedentary EMI
- Frail Elderly
- Early stage HD
- Palliative care
- Parkinson's Disease
- Cardiovascular conditions
- Osteoporosis
- Rheumatoid Arthritis

Environments

- EMI wards
- Residential care

Benefits & Features

- Seat depth adjustment
- Three seat angle options (10°, 15°, 20°)
- Interchangeable back options – Flat, Contoured and Waterfall
- Nine combinations of seat width/height
- Integral CareFlex Watercell Technology® pressure relief in seat as standard
- Simple, gas action controlled Back Angle Recline (BAR)
- Integral sliding footplate as standard
- Low profile, twin wheel braked castors for ease of portering
- Fixed covers

Size Options & Adjustments

- Three height settings (400, 440, 480mm)
- Three width settings (380, 430, 480mm)
- Three seat angle options (10°, 15°, 20°)

Options

- Flat back
- Contoured back
- Waterfall back

Accessories

- Block legrest
- Profiled soft headrest
- Shallow and deep soft headrest
- Pelvic strap
- Tray



HydroCare[®]

The CareFlex nursing chair

From CareFlex

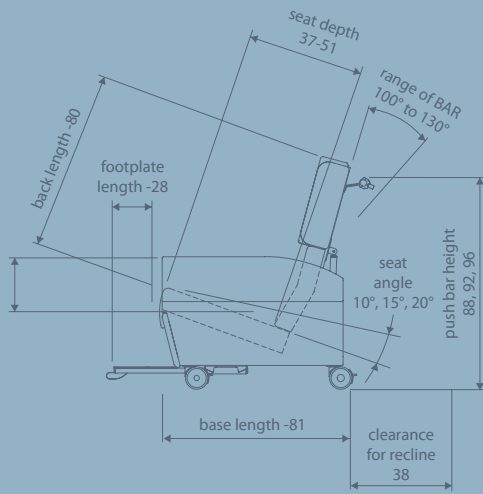
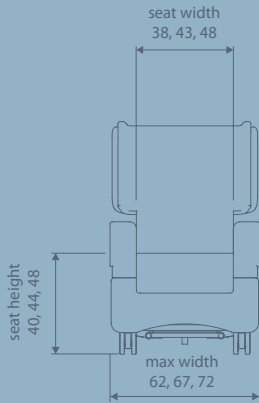

Product weight: 35kg
Maximum user weight: 160kg

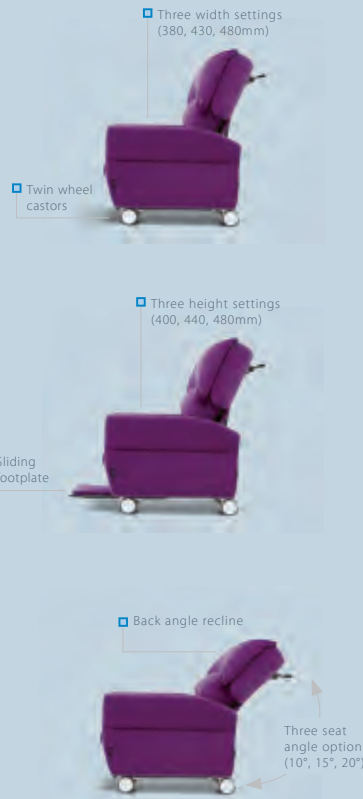

The Benefits

- Simple day to day operation once seat depth has been configured for the client
- Pelvic stabilization through inclined seat, reducing the tendency for the client to slide into sacral sitting and incur skin damage through shear
- The amount of lateral support required by the client can be accommodated by a simple change to back shape/option. No additional accessories required
- Can be sized to fit the client, stabilizing their posture, improving support and comfort
- Proven pressure relief fitted as standard. No additional inserts or cushions required
- Client position can be easily and frequently changed for different activities, encouraging functionality and independence
- Easy to push, improving client choice to use communal or private areas in their environment
- Soft and friendly appearance and easy to clean
- Above all, the HydroCare offers high levels of comfort to encourage security, relaxation and calmness

The HydroCare[™] has passed BS EN 15373:2007, test level 2 static load and fatigue tests



Rehabilitation category winner
BHTA Excellence Awards 2008, 2009 & 2010



Rehabilitation category winner BHTA Excellence Awards 2008, 2009 & 2010

Unit 1, Templer House
King Charles Business Park
Old Newton Road
Heathfield
Newton Abbot
Devon TQ12 6UT

Tel: 00 44 (1)626 836440
Fax: 00 44 (1)626 836441
A CliniMed® Group Company

CareFlex is a member of the
British Healthcare Trades Association.
For more information visit
www.bhta.com or call 020 7702 2141

© CareFlex Ltd 2011

Company registered in England No. 02650254 Registered Office: Cavell House, Knaves Beech Way, Loudwater, High Wycombe, Bucks HP10 9QY

CareFlex Ltd. reserves the right to alter specification without prior notice. The design and construction of all products and samples supplied by the company and all the product names are the intellectual property of CareFlex Ltd. and/or CliniMed (Holdings) Ltd. In the event of unauthorised copying, reproduction, use or passing off of the company's intellectual property, the company will pursue its legal remedies to the fullest extent.

CareFlex®, CareFlex WaterCell Technology®, HydroCare® and the CareFlex wavy lines logo are all trademarks of CliniMed (Holdings) Ltd.



This leaflet is printed on paper produced from sustainable sources using biodegradable, vegetable inks.

Distributor details:

www.careflex.co.uk
enquiries@careflex.co.uk

Customer Careline: 0800 0186440

HC 08/11