



# CareFlex

FLEXIBILITY IN A WORLD  
OF MIXED ABILITY

## HydroCare™ User Instructions

# UI

These are the user instructions for the CareFlex HydroCare chair. Please read them carefully before setting up and using the chair and keep them in a safe place for future reference.

These instructions include details of the performance of the chair. If the chair should start behaving outside of its intended performance, show signs of damage or excessive wear, or otherwise feel unsuitable, please take it out of service and contact CareFlex or your CareFlex Distributor immediately.

The HydroCare chair is designed for use in nursing home environments, specifically for those clients who are still ambulant but who require a high level of security and comfort. The chair has a built-in pressure management system based on CareFlex's patented WaterCell Technology® in the seat.



### **WARNING**

A level of supervision appropriate to the client's abilities must be applied at all times.

## The HydroCare Chair

The seat width and seat to floor height will be factory set as per the dimensions taken at the time of assessment/prescription. These dimensions cannot be adjusted.

The HydroCare has three seat angle settings, 10°, 15° and 20°. The seat angle will be selected at assessment to suit the client but it can be adjusted at a later date. Please see the further instructions.

Seat depth can be adjusted to suit the client between the ranges illustrated on the diagrams below. Seat depth will have been measured during assessment and the chair delivered with the seat depth set accordingly. However, seat depth must be checked to ensure the client is getting full support to the back and is not sacral sitting.

There is a back angle recline facility to provide different sitting positions for different activities. This is controlled by a release lever activating an adjustable gas spring.

There are three back options for the chair. The flat and contoured backs are made from shaped foam. The contoured back has additional pads on the sides to give moderate lateral control. The waterfall back consists of three overlapping fibre filled pillows which provide soft, conforming support.

## Identification

Each HydroCare chair has a unique chair number which must be quoted during any correspondence with CareFlex or your local CareFlex Distributor. This is on a silver foil label on the square tube of the back frame.

## Set-up and Adjustment

Use a cloth tape measure to measure the client as you are setting up the chair. This will help limit the need for any re-adjustment. Seat width, height and depth will have been factory set on the HydroCare according to dimensions taken when the chair was assessed. Seat depth, which is critical for client comfort and safety, must be checked to ensure it is correct and adjusted if necessary.

Regularly check the HydroForm set up to ensure it is working as intended and the client is benefiting from the pressure management solutions which are built into the chair.

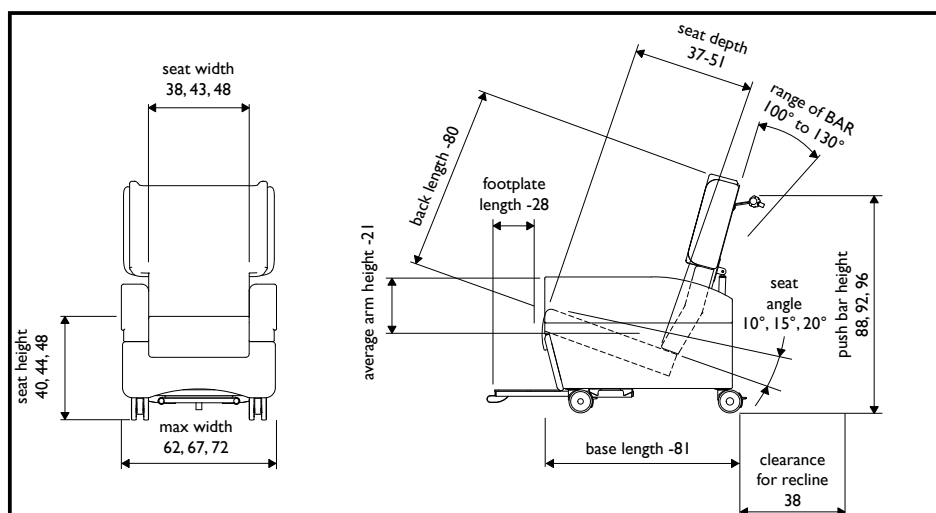

**Max user weight = 160kg**

## I. Seat Height and Width

If the client can raise to standing themselves or with minimal assistance, the seat height should be set so that the client's feet rest flat on the floor and the underside of their thighs are in contact with the full length of the seat cushion. If the seat height is too high, the client's heels will be lifted off the floor and pressure will build up along the underside of their thighs. If the seat is too low, their knees will be raised and there will be no contact between the back of their thighs and the seat cushion. This will increase the pressure on their bottom and sacrum and could cause discomfort at the hips.

If the client is less ambulant and is being regularly portered then seat height can be set relative to the sliding footplate. Again, ensuring the foot is flat and fully supported is important.

Seat width affects side-to-side pelvic stability. This is important as the spine should line up centrally with the pelvis. If the pelvis is free to move to one side then the client's spine will usually lean in the opposite direction. As gravity pulls the client over, the spine will begin to curve to compensate as the client tries to keep their head level. The client will take on a characteristic 'S' shaped spine or scoliosis. The more upright the user's trunk is, the more critical pelvic stability becomes. It is, therefore, important to use a chair with the correct seat width in order to position the pelvis properly.

Seat width should always allow for a little bit of movement as the client's body weight and posture naturally shifts throughout the day. If the client is held in a rigid position they will quickly tire and experience discomfort.

Seat height and width will have been measured at assessment and the chair set up for the client prior to delivery.

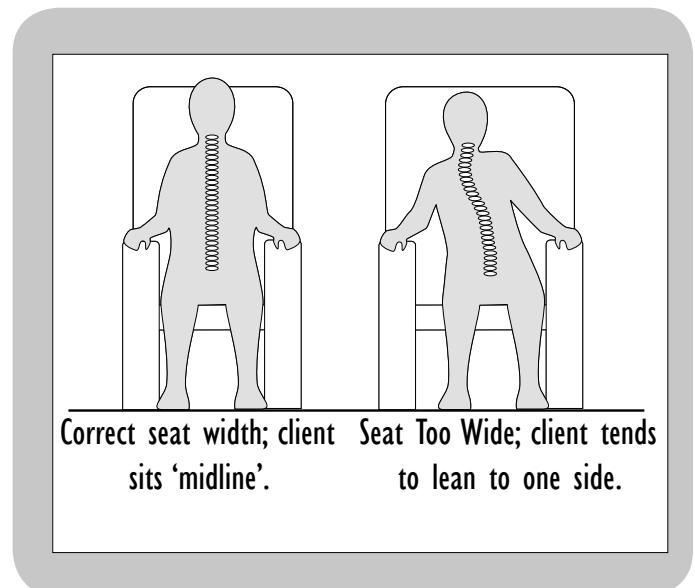
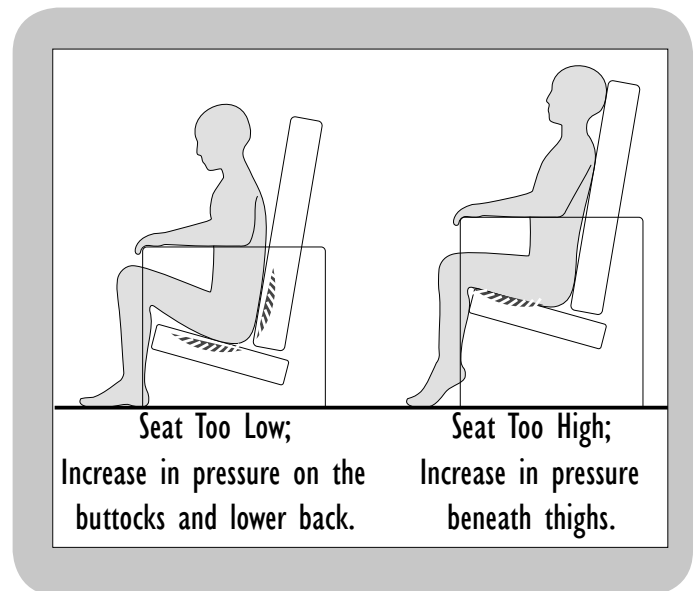

## 2. Seat Depth

It is important to set seat depth correctly in order to prevent 'sacral sitting' and to achieve the best distribution of weight between the client and the chair. Sacral sitting occurs when the pelvis tilts backwards so that the lower back (sacrum), as well as the bottom, is resting on the seat cushion. The sacral area can be susceptible to pressure problems. Sacral sitting will occur if the seat depth is too long. If the seat depth is too short then the client's body weight will be concentrated in too small an area.

With the HydroCare seat depth also affects arm height. The chair has been sized so that as the seat depth is increased it is matched by a proportionately higher arm height.

Seat depth should be set with the client's bottom positioned firmly at the back of the seat cushion so that their lower back and lumbar is supported by the back cushion. There needs to be a two or three finger gap between the client's calf and the front of the seat cushion for comfort.

If the client already has a chair or wheelchair with the correct seat depth, measure this size and use it to set up the HydroCare

Seat depth is adjusted by moving the back of the chair over the seat unit. The front edge of the seat will stay in the same place. The seat depth mechanism is controlled by two handwheels on the underside of the seat board, one each side of the seat.

Before adjusting seat depth, apply the brakes on all castors. Do not attempt to adjust seat depth when someone is sitting in the chair.

To adjust seat depth, loosen the handwheels until they are felt to hang freely from the underside of the seat. They do not need to be removed.

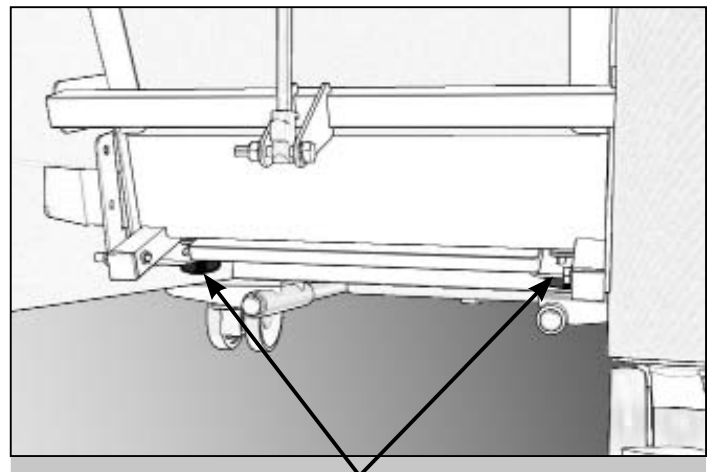
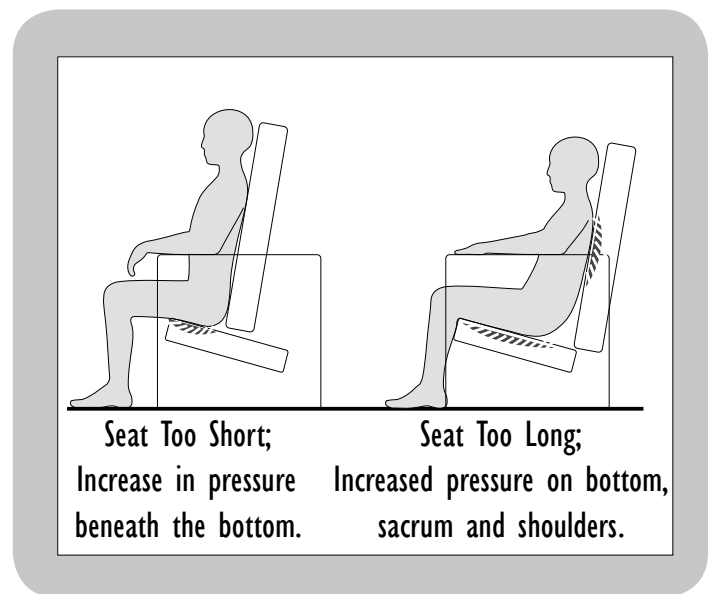

Undo the handwheels on the underside, outer edges of the seat board.

Hold onto the square tube at the back of the seat depth frame, each side of the gas action and push/pull the seat back to the desired position.

Once the back is in the correct position ensure that it looks square and is not twisted. Tighten the handwheels on the underside of the seat board to lock the back in place and therefore fix the seat depth.

## 3. Day to Day Use

### 3a. Brakes & Castors

The HydroCare is fitted with castors which make them suitable for portering clients on smooth, level ground.

When portering a client in a CareFlex chair, a pelvic strap must be fastened around the client and correctly adjusted.

The chair should not be pushed over large steps or thresholds, or over rough or uneven ground. Suitable surfaces for portering clients in the chair are level indoor surfaces and outdoor surfaces such as smooth, even asphalt and large paving slabs.

Deep pile carpet will require additional effort to move the chair and should be avoided.

The HydroCare should not be used outdoors in damp or wet weather. The chairs should not be used to porter clients on slopes or inclines.

Before transferring in and out of the chair the brakes on the castors should be applied. Always ensure that at least two of the castor brakes are applied before a client transfers in or out of the chair.

To apply the brakes begin by generally positioning the chair. Once the chair is in the desired position push it forward slightly. This will swing the rear castors around to reveal the brake levers. Press down the end of the levers to lock the brakes.

To release the brakes, gently kick the top of the brake lever so that it clicks flat.

**Do not attempt to push the chair with the brakes applied as this can damage the castors and stress the frame of the chair.**

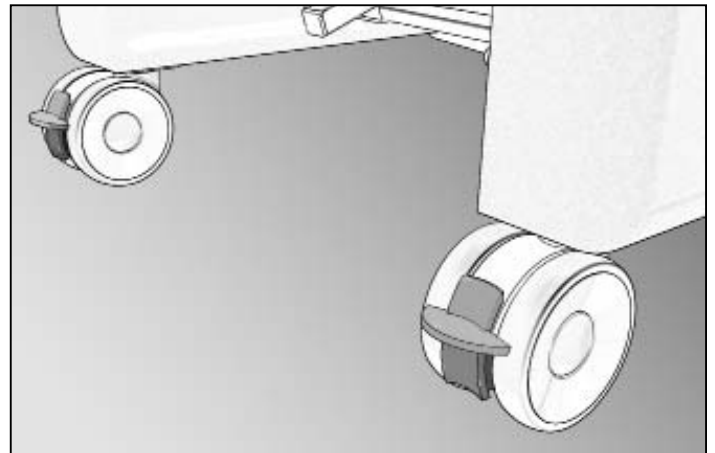

Each castor has a brake. Apply at least two before transfer.

### When portering a client;

- Bring the back of the chair to an upright position. This will put the handle in a more appropriate position and make the chair easier to push.
- Ensure the client's feet are off the floor by placing them on the sliding footplate.
- Use a pelvic strap to keep the client safely positioned in the chair, especially if they are likely to become agitated as they are being portered.

The chair should not be pushed over large steps or thresholds, or over rough or uneven ground. Suitable surfaces for portering clients in the chair are level indoor surfaces and outdoor surfaces such as asphalt and large paving slabs. CareFlex chairs should not be used outdoors in damp or wet weather.

The chairs should not be used to porter clients on slopes or inclines.

A risk assessment should be carried out for each client and portering consideration, taking into account the combined weight of the client and the chair and the client's condition, especially any agitated movement which may de-stabilize the chair or lead to injury through entrapment or impact with doorways, hand rails etc.

### 3b. Back Angle Recline

The HydroCare has an angle adjustable back. When the back is fully upright, the angle at the client's hips will be approximately 100°. However, because of the contoured profile of the back, the client will find this a comfortable position for mealtimes, activities and for preparing to raise to standing.

The back angle can be reclined to give a 130° angle at the hips. This is a comfortable position for resting. However, because of the fixed seat angle the chair still offers security for clients sitting for a long period of time.

To adjust the back angle recline, squeeze the lever on the HydroCare push handle. This will unlock the gas action and allow the back to be tilted to the required angle. When the client is in a comfortable position, let go of the lever and the back angle will lock in position.

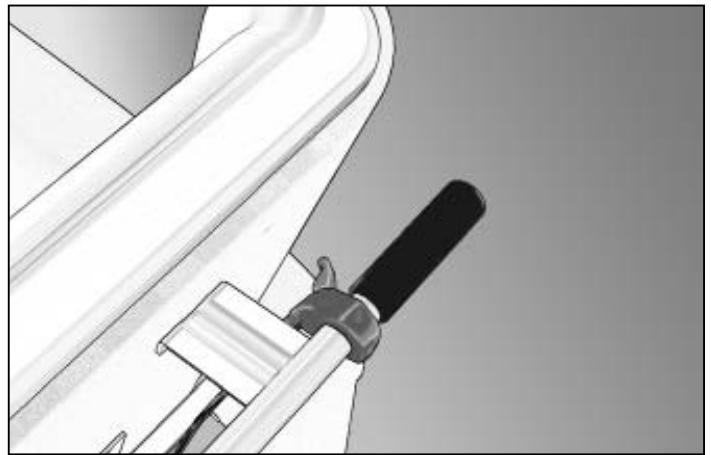

Back angle can be adjusted by squeezing the lever on the push handle.

**Always warn the client before adjusting the back angle recline to ensure they do not become distressed or agitated.**

### 3c. Sliding Footplate

When pushing a client in the chair their feet must be raised so that they do not drag on the floor. The sliding footplate allows the feet to be raised off the floor for portering. It can also be used to set seat height from if the client has a very short lower leg length.

The sliding footplate is fitted between the chair arms. It can be pulled out for positioning the client's feet when the chair is being moved and pushed back under the chair when the client wants to raise to standing.

The footplate has a padded top to provide a soft warm surface if the client is not wearing shoes.

Pull the webbing loop on the front edge of the footplate to bring it out for portering. Push the footplate back under the chair before transfer.

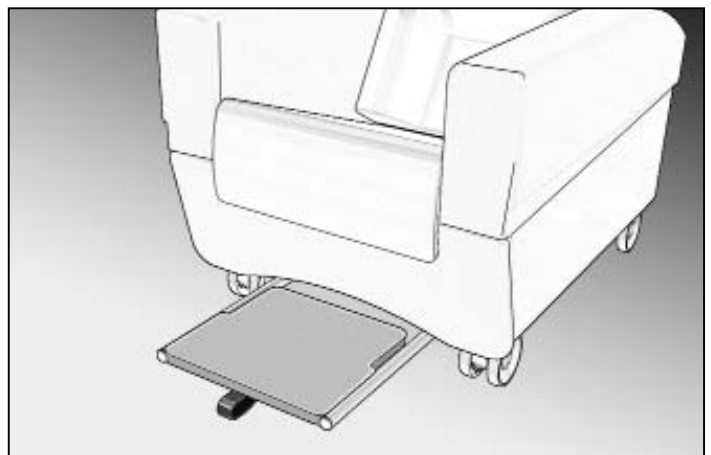

Sliding Footplate.

#### **SAFETY NOTE:**

**The footplate should not be stood on during operation or transfer. Do not leave a client unsupervised in the chair with the footplate pulled out if they are likely to try to stand as they could slip off the board and fall.**

## 4. Accessories

### 4a. Headrests

The HydroCare can be fitted with a range of soft headrests. These are;

- Shallow headrest for basic head support.
- Deep headrest for more support for those with a kyphotic profile.
- Profiled Soft headrest with semi-circular cut-out to give conforming support around the head and neck.

Each headrest pillow is a soft, fibre filled cushion to support the back of the client's head. A single strap on the top edge of the headrest wraps around the centre of the push handle to control the height of the headrest and hold it in position on the chair.

Two thicknesses of pillow are available. Headrest choice will depend on the client's posture and the gap between the client's head and the chair back. Aim to use a headrest which fills this gap but which does not push the client's head and shoulders forward.

Once the client is sat in the chair, move the headrest to where they find it to be the most comfortable and supportive. As the client holds their position, undo the Velcro tabs on the end of the strap. Take the slack out of the strap and re-attach it around the push bar with the velcro holding the strap securely in place.

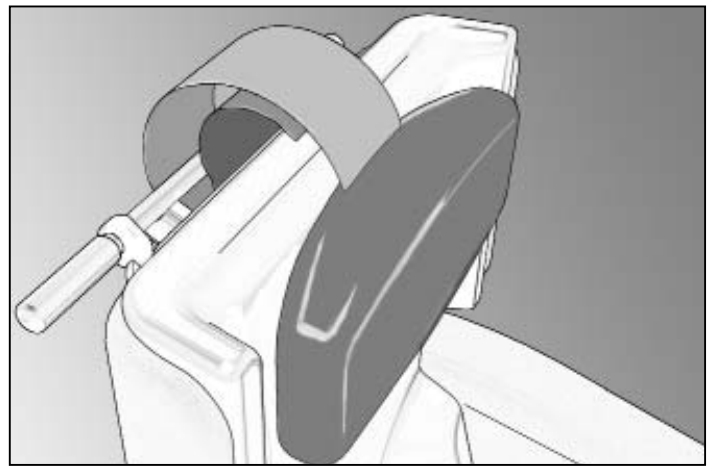

The straps on the headrest pillow fit over the chair back and velcro in place.

## 4b. Block Legrest

A block legrest accessory can be used with the HydroCare to elevate the client's legs.

The block legrest incorporates Reflexions foam in the top surface for pressure relief. The legrest consists of a solid block which prevents the client trapping their legs under the seat of the chair.

The block legrest comes in three heights to match seat height.

The block legrest can be attached to the chair for portering. Straps on the block legrest are fitted through the D rings attached to the sides of the front face panel of the chair.

Open the velcro closure on the straps, fit the straps through the D rings and fold them back to join the velcro closure.

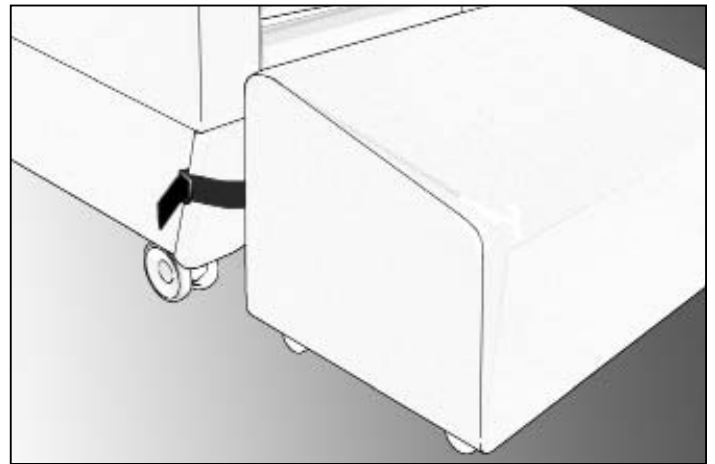

Fit the velcro straps through the D rings and fold them back on themselves to hold the position.

**NOTE:** The block legrest must never be positioned in front of the chair to act as a restraint or to stop the client getting out of the chair.

## 4c. Tray

The tray accessory is a laminated wooden activity surface which rests across the arms of the chair.

The tray is held in position with straps which fit through D rings mounted on the sides of the chair.

The rear straps are length adjustable. Shortening the straps will position the tray closer to the client whilst lengthening them will allow the tray to be moved away. When positioning the tray, ensure the client cannot get their arms trapped under the tray.

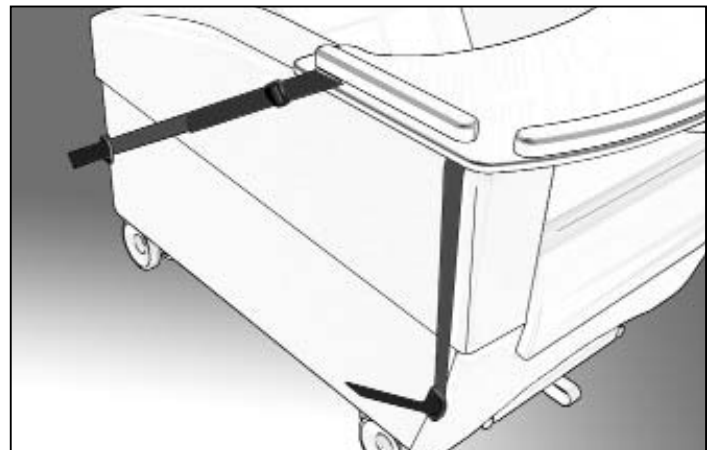

Fit the front and rear straps through the D rings and fold them over to secure. Adjust the tension in the rear strap to move the tray forwards and backwards.

**NOTE:** The tray must never be positioned in front of the chair to act as a restraint or to stop the client getting out of the chair.

## 4d. Pelvic Strap

## 4e. Pelvic Strap Fitting

Pelvic straps are intended to be used as positioning aids to help keep the client stable in the chair with a vertical pelvic posture, reducing the tendency to sacral sit and limiting soft tissue damage through the effect of shear.

The pelvic strap is attached to the square tube of the seat depth adjustment frame. The mounting points for the pelvic strap also control pelvic strap length adjustment.

Due to the nature of pelvic strap use, and in order to prevent misuse, the length of the pelvic strap can be adjusted and set by the healthcare professional to ensure a regular and constant tension on the strap and prevent it being adjusted to that it sits loose around the client, which is potentially harmful.

Adjust the pelvic strap so that there is 10 to 15cm of loose webbing on each side of the buckle and join the two halves of the side release buckle together.

Fit the straps between the chair back and arms and position them close to the square bar running across the back of the chair.

The tri-glide buckle needs to be slid along the webbing so that it is behind the square bar. Loop the webbing over the bar and feed it back through the buckle.

Adjust the tension on the strap to the desired length. Once at the correct length, fold the loose end of the webbing back over the majority of the buckle and feed it under the last bar of the tri-glide. This will ensure that the strap does not slowly loosen over time.

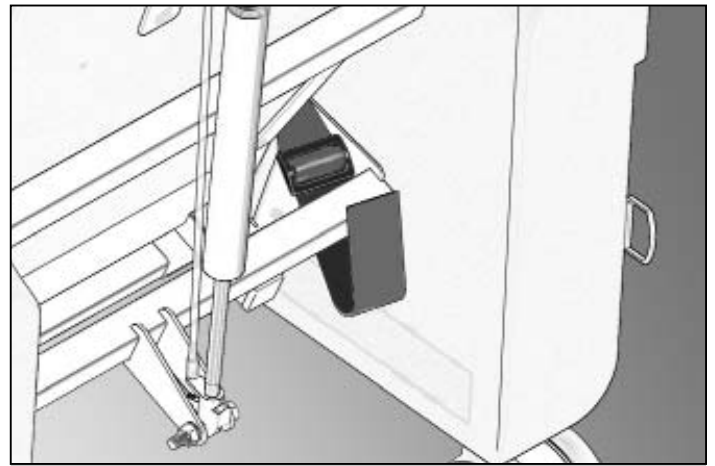

Pelvic strap with tri-glide on webbing strap.

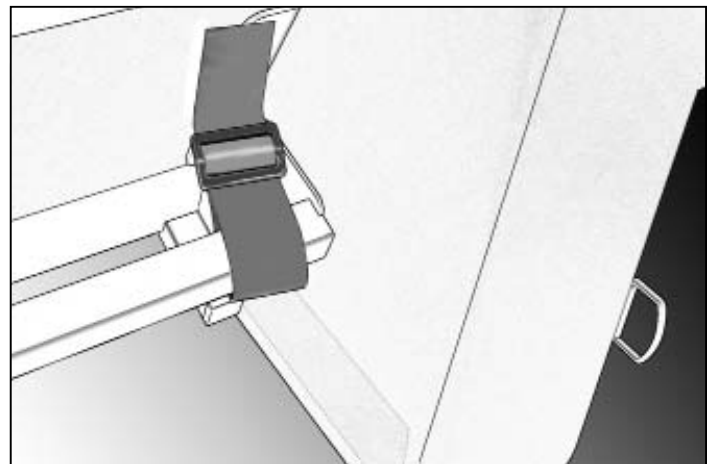

Loop the strap around the square bar and back through the tri-glide.

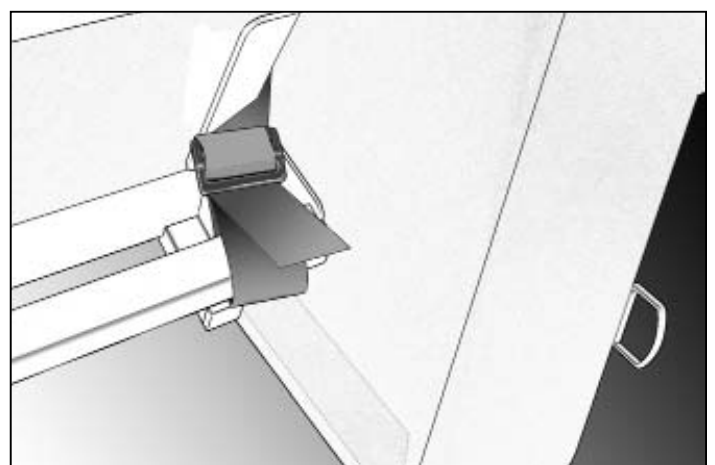

Feed the webbing strap back under the last bar of the tri-glide to hold the strap in place.

## 4f. Pelvic Strap Day to Day Use

The pelvic strap has a side release buckle. The buckle comes in two parts which slot together. Tabs on the side of the buckle lock the two halves together. To open the buckle, press the tabs on the sides at the same time. The buckle should pop apart easily.

Before transfer into the chair drape the ends of the pelvic strap over the arms of the chair to make them easy to reach once the client is in the chair.

Once the client is in the chair, fit the two halves of the buckle together and ensure they click positively together. If additional tension is required, pull the loose ends of webbing on each side of the central side release buckle.

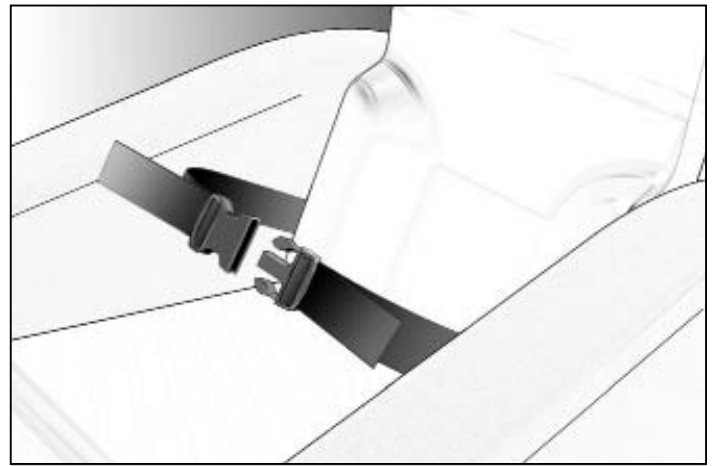

Dual adjustable buckle with adjustment on both sides to keep buckle centrally located.

### SAFETY NOTE

**A pelvic strap must never be used as a restraint. Full supervision must be provided when a pelvic strap is being used.**

**The pelvic strap must be regularly checked to ensure it has not worked loose.**

**The pelvic strap must be correctly tensioned so that it supports the user but does not restrict breathing, cause discomfort or interfere with any abdominal implants.**

**If the strap is too loose there will be a danger of the client sliding under the strap and becoming trapped.**

## 5. Seat Angle Adjustment

The angle of the seat unit of the HydroCare has three settings; 10°, 15° and 20°.

Seat angle can be used to encourage greater pelvic stability. Increasing the seat angle encourages the pelvis back into the seat to encourage an upright position and reduce sacral sitting and the effect of shear.

However, increasing seat angle can also make it difficult for the client to get out of the chair, reducing independence and functionality.

It is therefore important to select a seat angle which is appropriate to the client's needs, balancing sitting stability with functionality and independence.

The Hydrocare will have been built according to the seat angle selected at assessment. However, the seat angle can be adjusted in the field if necessary.

Adjusting seat angle is a two person operation and requires two 13mm spanners.

Locate the bolts at the end of the seat side rails at the back of the chair. The bolts pass through the rails and into the seat angle adjustment brackets on the back of the chair. Whilst someone supports the back of the chair by holding on to the push handle, undo the bolts, keeping hold of the nuts and washers.

Raise or lower the seat to the required angle and re-fit the bolts through the rails and the appropriate holes in the seat angle brackets. The same hole must be selected on both sides of the chair.

There must be washers between the rails and the brackets and between the bolt heads and nuts and the metalwork.

Ensure the bolts are fully tightened with spanners before the chair is used.

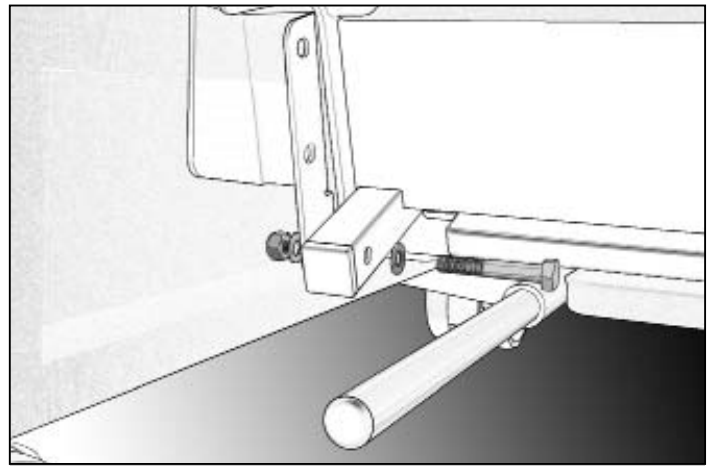

Use two 13mm spanners to undo the two bolts controlling seat angle.

# Care & Maintenance

- Every time it is used, check the chair over for signs of damage or excessive wear. If the chair shows signs of excessive wear, damage or incorrect performance, please take it out of service immediately and contact CareFlex .
- If the client is experiencing severe discomfort, do not use the chair. Take it out of service immediately and contact CareFlex or your local CareFlex Distributor.
- The chair is upholstered in high quality material which is waterproof and fire retardant. However, do not store or use the chair in damp or wet areas.
- Do not attempt to carry out any structural maintenance or adjustment of the chair or its accessories without consulting CareFlex.
- Refer to the CareFlex Fabric Guide for the appropriate cleaning instructions for the material in which the chair is upholstered.

## Important Safety Information

- Please take the time to familiarise yourself with all the aspects of the chair and its functions before using the chair.
- Do not 'ride' on the push handles or subject them to excessive loads
- Do not sit on the legrest or subject it to excessive loads
- Do not attempt to stand on the footplate.
- Do not tip the chair backwards to ascend steps or overcome thresholds, especially if a client is sat in the chair.
- Always ensure that the client's feet do not drag on the ground when the chair is moved by positioning their feet on the sliding footplate.
- Always ensure that there are no obstructions under the chair and that there is plenty of space around the chair before using the back angle recline facility.
- Always apply at least two brakes when the client is transferred to or from the chair.
- Always try to avoid storing or using the chair in areas where it may obstruct exits or passageways.
- The HydroCare must never be used in motor vehicles for client transportation.

