

Care & Maintenance

- Every time it is used, check the chair over for signs of damage or excessive wear. If the chair shows signs of excessive wear, damage or incorrect performance, please take it out of service immediately and contact CareFlex .
- If the client is experiencing severe discomfort, do not use the chair. Take it out of service immediately and contact CareFlex or your local CareFlex Distributor.
- The chair is upholstered in high quality material which is waterproof and fire retardant. However, do not store or use the chair in damp or wet areas.
- Do not attempt to carry out any structural maintenance or adjustment of the chair or its accessories without consulting CareFlex.
- Refer to the CareFlex Fabric Guide for the appropriate cleaning instructions for the material in which the chair is upholstered.

Important Safety Information

- Please take the time to familiarise yourself with all the aspects of the chair and its functions before using the chair.
- Do not 'ride' on the push handles or subject them to excessive loads
- Do not sit on the legrest or subject it to excessive loads
- Do not attempt to stand on the footplate.
- Do not tip the chair backwards to ascend steps or overcome thresholds, especially if a client is sat in the chair.
- Always ensure that the client's feet do not drag on the ground when the chair is moved by elevating the legrest to lift their feet off the floor or using the sliding footplate.
- Always ensure that there are no obstructions under the chair and that there is plenty of space around the chair before using the back angle recline facility.
- Always apply at least two brakes when the client is transferred to or from the chair.
- Always try to avoid storing or using the chair in areas where it may obstruct exits or passageways.
- The HydroForm must never be used in motor vehicles for client transportation.
- Do not charge the chair's batteries when a client is sat in the chair (Motorised versions).
- Do not move the chair if the charging lead is connected between the chair and mains power supply.



HydroForm User Instructions

UI

These are the user instructions for the CareFlex HydroForm chair. Please read them carefully before setting up and using the chair and keep them in a safe place for future reference.

These instructions include details of the performance of the chair. If the chair should start behaving outside of its intended performance, show signs of damage or excessive wear, or otherwise feel unsuitable, please take it out of service and contact CareFlex or your CareFlex Distributor immediately.

The HydroForm chair is designed for use in nursing home environments, specifically for those clients who are still ambulant but who require a high level of security and comfort. The chair has a built-in pressure management system based on CareFlex's patented WaterCell Technology® in the seat and Reflexion foam in the seat and lumbar area.

SPECIAL NOTE FOR MOTORISED HYDROFORMS

When the chair is first delivered, charge the batteries before it is used. Similarly, if the chair has not been used for a long time, charge the batteries. Establish a regular charging program to maintain battery health. Please refer to the guidelines at the end of these instructions.

WARNING

A level of supervision appropriate to the client's abilities must be applied at all times.



The HydroForm Chair

The HydroForm has a fixed seat angle (15 degree reclined from horizontal) for patient comfort and security. The chair has a simple set-up procedure and regular adjustments can be made easily. The seat width and seat to floor height will be factory set as per the dimensions taken at the time of assessment/prescription. These dimensions can be adjusted by a suitably trained person. Seat depth can be adjusted to suit the client. There is a back angle recline facility to provide different sitting positions for different activities. There are two back height options, high back and low back.

There are two formats of the HydroForm available, manual and motorised. The manual version of the HydroForm has a back angle recline facility which is controlled by a locking gas action. The manual version can be fitted with a ground level sliding footrest for portering. A height adjustable independent legrest or fixed height block legrest can be used in conjunction with the HydroForm, even when fitted with the sliding footplate accessory.

On the motorised version of the HydroForm the back angle recline function and integral elevating legrest are controlled by electric actuators which are powered by a rechargeable 24V battery system.

Identification

Each HydroForm chair has a unique chair number which must be quoted during any correspondence with CareFlex or your local CareFlex Distributor. This is on a silver foil label on the back of the seat depth adjustment frame. On older chairs the number is on a label on the seat board. It can be viewed by carefully lifting up the front edge of the seat cushion.

Set-up and Adjustment

Use a cloth tape measure to measure the client as you are setting up the chair. This will help limit the need for any re-adjustment. Seat width and seat to floor height will have been factory set on the HydroForm according to dimensions taken when the chair was assessed. Seat length, which is critical for client comfort and safety, will need to be adjusted to suit the client.

Regularly check the HydroForm set up to ensure it is working as intended and the client is benefiting from the pressure management solutions which are built into the chair.

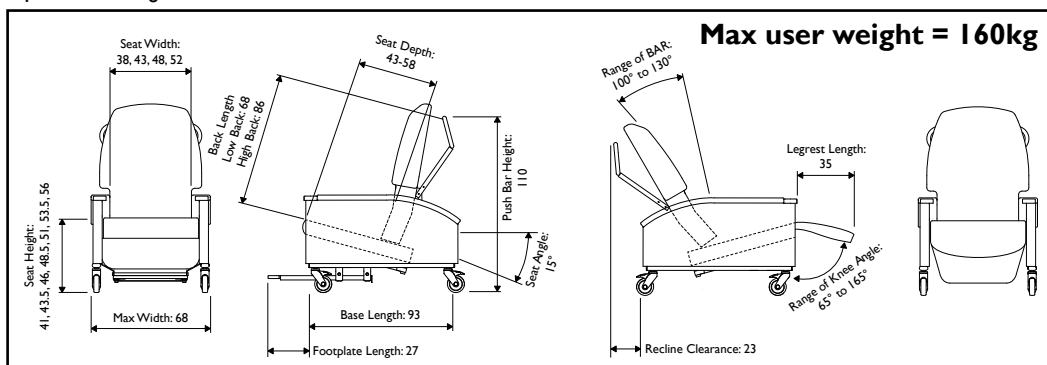

5. Charging Batteries

(motorised option HydroForm only)

To charge the batteries of the HydroForm;

- Fit the jack plug on the end of the charger lead into the socket on the side of the hand control unit of the HydroForm.
- Plug the charger into a 240V AC mains electric supply and switch the power onto the charger. Leave the chair on charge for at least six hours, preferably over night and for at least 24 hours if it is suspected that the batteries have been drained.
- At the end of the charging cycle, switch off the charger and disconnect all leads and plugs.

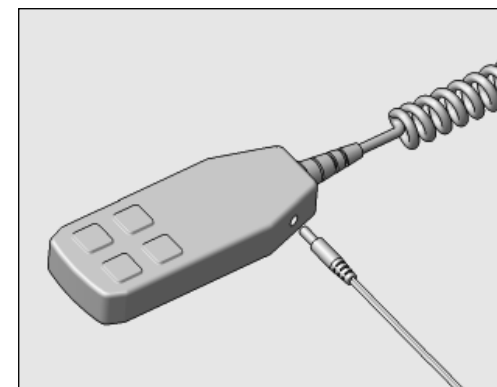

Battery charge lead being fitted into the handset to charge the chair's batteries.

Battery health can be affected by temperature. If the chair has been stored in a cold area, charge batteries before use.

Before the battery charger is used, check it for signs of cracks or other damage. Do not use a charger which shows signs of damage.

Establish a regular routine for battery charging. A full charge can take up to 24 hours so charging over night is recommended. The battery will sound a warning signal when it is drained below 70% of its capacity. Do not wait to hear this signal but charge the batteries as soon as possible after it is heard.

CareFlex motorised chairs are supplied with a charger. Only chargers supplied by CareFlex should be used to charge CareFlex chairs. Do not use a CareFlex charger to charge other products.

DO NOT

- **Leave the charger connected between the mains and chair with the mains power switched off.**
- **Move the chair with the charger connected between the chair and the mains.**
- **Charge the batteries when the client is sat in the chair.**
- **Operate the chair whilst the batteries are on charge.**

If the motors do not work after 24 hours of full charging take the chair out of service and contact CareFlex immediately.

4b. Pelvic Strap

SAFETY NOTE

A pelvic strap can be fitted to the HydroForm to help the client maintain a good sitting position. A pelvic strap must never be used as a restraint. Full supervision must be provided when a pelvic strap is being used.

The pelvic strap must be regularly checked to ensure it has not worked loose.

The pelvic strap must be correctly tensioned so that it supports the user but does not restrict breathing, cause discomfort or interfere with any abdominal implants. If the strap is too loose there will be a danger of the client sliding under the strap and becoming trapped.

4c. Sliding Footplate

(Manual option HydroForm only)

When pushing a client in the chair their feet must be raised so that they do not drag on the floor. The sliding footplate allows the feet to be raised off the floor for portering. It can also be used to set seat height from if the client has a very short lower leg length.

The sliding footplate is fitted between the chair outriggers. It can be pulled out for positioning the client's feet when the chair is being moved and pushed back under the chair when the client wants to raise to standing.

A pad is available to fit on the footplate to provide a soft warm surface if the client is not wearing shoes.

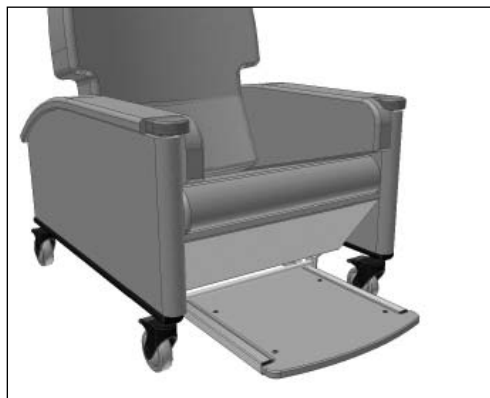

Sliding Footplate.

SAFETY NOTE:
The footplate should not be stood on during operation or transfer. Do not leave a client unsupervised in the chair with the footplate pulled forwards if they are likely to try to stand as they could slip off the board and fall.

I. Seat Height and Width

If the client can raise to standing themselves or with minimal assistance, the seat height should be set so that the client's feet rest flat on the floor and the underside of their thighs are in contact with the full length of the seat cushion. If the seat height is too high, the client's heels will be lifted off the floor and pressure will build up along the underside of their thighs. If the seat is too low, their knees will be raised and there will be no contact between the back of their thighs and the seat cushion. This will increase the pressure on their bottom and sacrum and could cause discomfort at the hips.

If the client is less ambulant and is being regularly portered then seat height can be set relative to the sliding footplate. Again, ensuring the foot is flat and fully supported is important.

Seat width affects side-to-side pelvic stability. This is important as the spine should line up centrally with the pelvis. If the pelvis is free to move to one side then the client's spine will usually lean in the opposite direction. As gravity pulls the client over, the spine will begin to curve to compensate as the client tries to keep their head level. The client will take on a characteristic 'S' shaped spine or scoliosis. The more upright the user's trunk is, the more critical pelvic stability becomes. It is, therefore, important to use a chair with the correct seat width in order to position the pelvis properly.

Seat width should always allow for a little bit of movement as the client's body weight and posture naturally shifts throughout the day. If the client is held in a rigid position they will quickly tire and experience discomfort.

Seat height and width will have been measured at assessment and the chair set up for the client prior to delivery. If further adjustment is required, please contact your CareFlex Distributor.

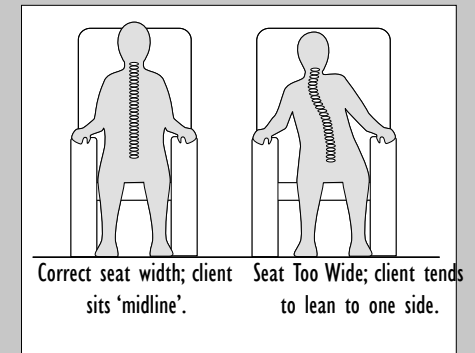
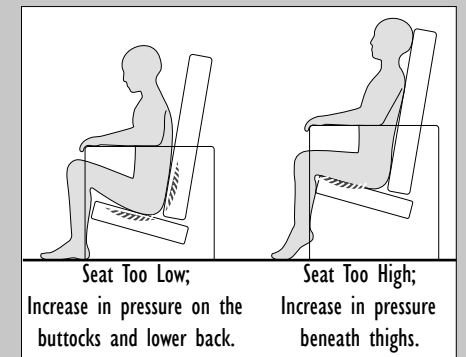

2. Seat Depth

It is important to set seat depth correctly in order to prevent 'sacral sitting' and to achieve the best distribution of weight between the client and the chair. Sacral sitting occurs when the pelvis tilts backwards so that the lower back (sacrum), as well as the bottom, is resting on the seat cushion. The sacral area can be susceptible to pressure problems. Sacral sitting will occur if the seat depth is too long. If the seat depth is too short then the client's body weight will be concentrated in too small an area.

With the HydroForm, seat depth also affects arm height. The chair has been sized so that as the seat depth is increased it is matched by a proportionately higher arm height.

Seat depth should be set with the client's bottom positioned firmly at the back of the seat cushion so that their lower back and lumbar is supported by the back cushion. There needs to be a two or three finger gap between the client's calf and the front of the seat cushion for comfort.

If the client already has a chair or wheelchair with the correct seat depth, measure this size and use it to set up the HydroForm.

Seat depth is adjusted by moving the back of the chair over the seat unit. The front edge of the seat will stay in the same place. The seat depth mechanism is controlled by a release lever on the rear left hand underside of the seat.

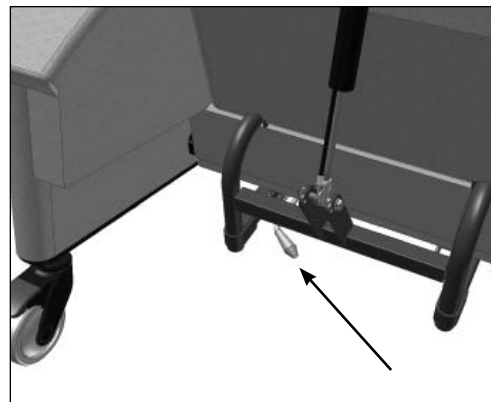
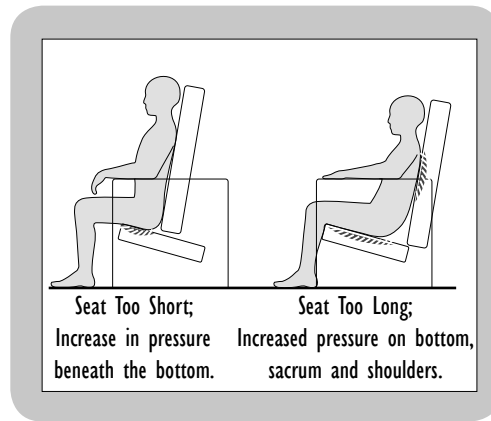

Release lever for adjusting seat depth.

To adjust seat depth, twist the seat depth release lever clockwise. Hold one of the curved tubes of the seat back frame and push/pull the back to the desired position.

Once the back is in the correct position let go of the lever. The back may 'jump' back slightly as the locking mechanism engages.

4. Accessories

4a. Headrest Pillow

The headrest pillow is a soft filled cushion attached to the backrest with two straps. The two straps help to keep the headrest stable and centrally positioned.

Two thicknesses of pillow are available. Headrest choice will depend on the client's posture and the gap between the client's head and the chair back. Aim to use a headrest which fills this gap but which does not push the client's head and shoulders forward.

Once the client is sat in the chair, move the headrest to where they find it to be the most comfortable and supportive. As the client holds their position, undo the straps by separating the Velcro tabs on the end of the straps from the Velcro sewn onto the back of the chair back. Take the slack out of the straps and re-attach them to the Velcro to hold the headrest position for the client.

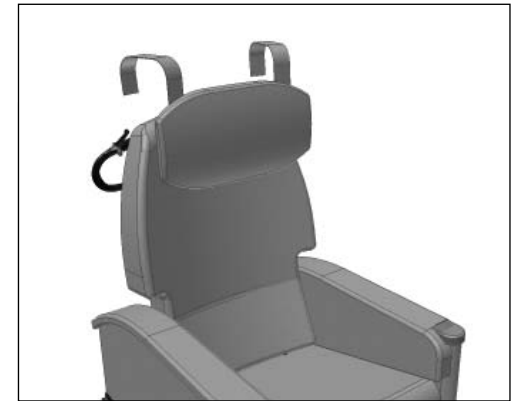

The straps on the headrest pillow fit over the chair back and velcro in place.

4b. Pelvic Strap

The pelvic strap is attached to the back angle recline pivot point and fits between the seat and lumbar cushion.

Use the buckle and tri-glides on the webbing strap to adjust the length and tension of the strap to suit the client. Close the strap by clicking the two halves of the buckle together. To open the straps press in the tabs on the side of the buckle and pull the two parts of the buckle apart.

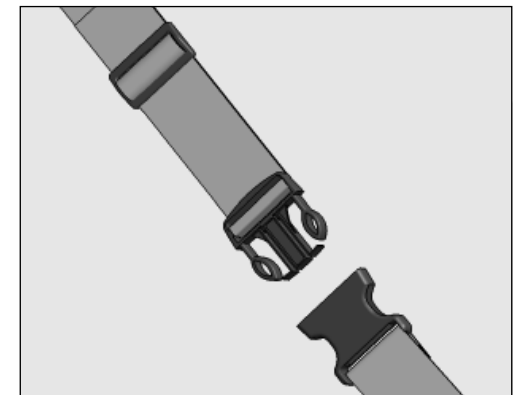

Pelvic strap with (L>R) tri-glide, male and female parts of the buckle.

3f. Height Adjustable Legrest

The height adjustable legrest allows the client's legs to be elevated to a comfortable height and angle whilst providing full support for the lower leg.

The legrest has two wheels at the back to allow for easy positioning and glides at the front to help keep the legrest in position.

The height of the legrest can be adjusted to match the height of the chair. Height is adjusted by pulling out the tube-locks which fit through the uprights of the legrest frame, adjusting the legrest to the desired height and re-fitting the tube-locks through the nearest set of holes.



Height adjustable legrest with tube locks to adjust height.

3g. Fixed Height Block Legrest

For clients with challenging behaviour, a fixed height block legrest is available. The legrest consists of a solid block which prevents the client trapping their legs under the seat of the chair. The block legrest comes in one height and the height of the chair should be set up to match.

The block legrest can be attached to the chair for portering. Straps beneath the front edge of the seat are fitted with buckles which connect to the buckles sewn into the sides of the block legrest. Attach the legrest to the chair with these straps and buckles and if necessary tighten the straps to hold the legrest firmly in place. When the legrest is not attached to the chair, fit the two parts of the buckles on the chair straps together to stop them getting tangled in the chair wheels.

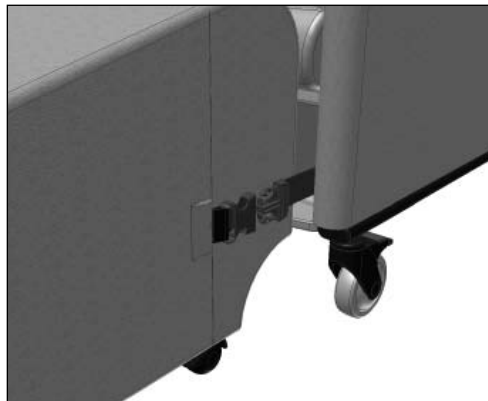

Fixed height block legrest with fitting to attach to chair.

NOTE:The block legrest must never be positioned in front of the chair to act as a restraint or to stop the client getting out of the chair.

3. Day to Day Use

3a. Brakes

Before transferring in and out of the chair the brakes on the castors should be activated. The castors have a full brake which locks roll and swivel. Always ensure that at least two of the castor brakes are applied before a client transfers in or out of the chair.

To apply the brakes begin by generally positioning the chair. Once the chair is in the desired position push it forward slightly. This will swing the rear castors around to reveal the brake levers. Press down the end of the levers to lock the brakes.

To release the brakes, gently kick the top of the brake lever so that it clicks flat.



Each castor has a full brake.

Do not attempt to push the chair with the brakes applied as this can damage the castors and stress the frame of the chair.

3b. Back Angle Recline

The HydroForm has an angle adjustable back. When the back is fully upright, the angle at the client's hips will be approximately 100 degrees. However, because of the contoured profile of the back, the client will find this a comfortable position for mealtimes, activities and for preparing to raise to standing.

The back angle can be reclined to give a 130 degree angle at the hips. This is a comfortable position for resting. However, because of the fixed seat angle the chair still offers security for clients sitting for a long period of time.

Always warn the client before adjusting the back angle recline to ensure they do not become distressed or agitated.

3c. Back Angle Recline, Manual Version

To adjust the back angle recline, pull in the lever on the HydroForm push handle. This will unlock the gas action and allow the back to be tilted to the required angle. When the client is in a comfortable position, let go of the lever and the back angle will lock in position.

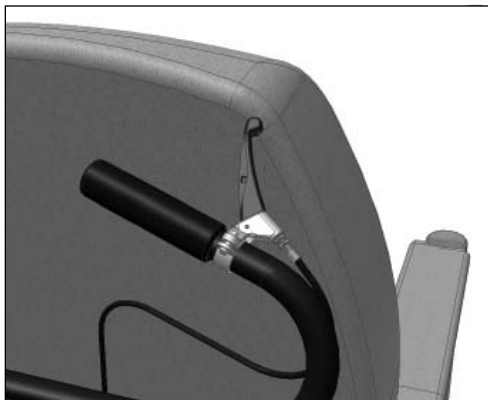

Back angle can be adjusted by squeezing the lever on the push handle.

3d. Leg Elevation, Manual Version

With the manual version of the HydroForm a legrest can be used to elevate the client's legs.

Two version of legrest are available, a height adjustable legrest and a fixed height block legrest. Both legrests incorporate Reflexions foam for pressure relief.



Manual chair with height adjustable legrest.

3e. Back Angle Recline & Legrest Elevation, Motorised Version

The motorised HydroForm has a 24V, rechargeable battery system which controls back angle recline and the operation of the integral elevating legrest.

The adjustment of the chair is controlled via a four button handset. Follow the symbols on the handset and press the appropriate button to recline the chair back or elevate the legrest.

The legrest has an articulating action which means that it extends as it elevates in order to maintain support under the client's legs.

The length of the legrest has been designed so that when elevated the client's heels will hang over the end of the legrest in order to avoid pressure build up on the heels.

In order to get the best out of the legrest it is critical that the seat depth is set up correctly for the client. If the seat depth is too short there will be less support offered by the legrest for the client's legs.

Please refer to the care and maintenance section of these instructions for details of battery charging.



Handset for controlling Back Angle Recline and legrest elevation on the motorised version.



Motorised option with legrest elevated.

IMPORTANT SAFETY NOTE FOR MOTORISED CHAIRS

Always ensure there are no obstructions in front or behind the chair before operating the elevating legrest or back angle recline. **DO NOT** attempt to elevate the legrest against any obstruction such as a wall or cupboard.