

Important Safety Information

- Please take the time to familiarise yourself with all the aspects of the chair and its functions before using the chair.
- Do not 'ride' on the push handles or subject them to excessive loads.
- Do not sit on the legrest or subject it to excessive loads.
- Do not attempt to stand on the footplate.
- Do not tip the chair backwards to ascend steps or overcome thresholds, especially if a client is sat in the chair.
- Always ensure that the client's feet do not drag on the ground when the chair is moved by elevating the legrest to lift their feet off the floor or using the sliding footplate.
- Always ensure that there are no obstructions under the chair and that there is plenty of space around the chair before using the back angle recline facility.
- Always apply at least two brakes when the client is transferred to or from the chair.
- Always try to avoid storing or using the chair in areas where it may obstruct exits or passageways.
- The HydroTilt must never be used in motor vehicles for client transportation.
- Do not charge the chair's batteries when a client is sat in the chair (Motorised versions).
- Do not move the chair if the charging lead is connected between the chair and mains power supply.



HydroTilt Quick Set-Up Guide

UI

The HydroTilt is a flexible seating system incorporating patented WaterCell Technology®, Reflexions® Foam and Tilt-in-Space technology to improve posture and pressure management for individuals with specialist seating requirements.

WARNING

A level of supervision appropriate to the user's abilities should be applied at all times.



Your HydroTilt Chair

When set up correctly:

- The HydroTilt should support the user in a comfortable position.
- The Tilt-in-Space and Leg Elevation features should operate smoothly and precisely.

For your HydroTilt to perform correctly it is essential that you have the correct size of chair from the range to suit the client. See the table below to check sizes to user requirements.

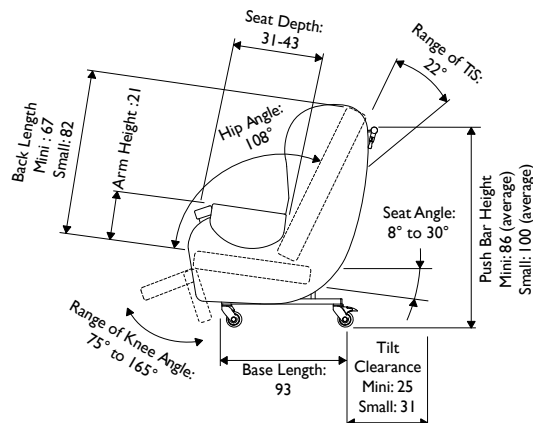
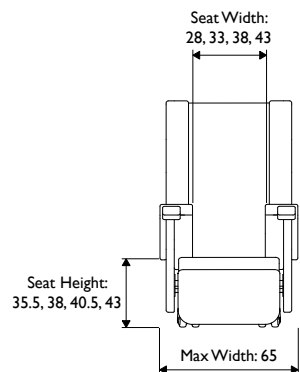

Weights	MINI HYDROTILT	SMALL HYDROTILT
Max User Weight	75kg	75kg
Product Weight	40kg	45kg

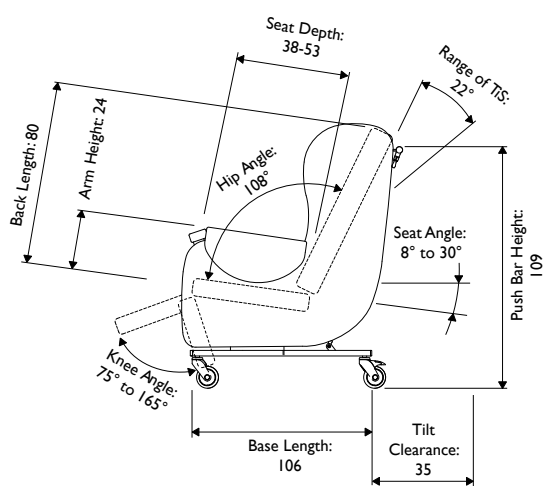
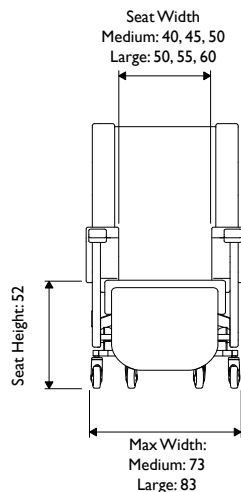

Weights	MEDIUM HYDROTILT	LARGE HYDROTILT
Max User Weight	160kg	160kg
Product Weight	50kg	55kg

LOOKING AFTER YOUR HYDROTILT

Care & Maintenance

- When the chair is delivered and every time it is used, check the chair over for signs of damage or excessive wear.
- If your chair shows signs of excessive wear, damage or incorrect performance, please take it out of service immediately and contact CareFlex or your local CareFlex Distributor.
- If the client is experiencing severe discomfort, do not use the chair. Take it out of service immediately and contact CareFlex or your local CareFlex Distributor.
- The HydroTilt is upholstered in high quality material which is waterproof and fire retardant. However, do not store or use the chair in damp or wet areas.
- Do not attempt to carry out any structural maintenance or adjustment of your HydroTilt or its accessories without consulting CareFlex or your local CareFlex Distributor.

Full details of accessory set up can be found in the HydroTilt Accessories User Instructions booklet. Details of cover material care and maintenance can be found in the Fabric Guide. Both are available in hard copy on request from CareFlex, or are free to download at www.careflex.co.uk.

Look after your HydroTilt and it will provide years of trouble-free service.

Identification

Each HydroTilt chair has a unique chair number which must be quoted during any correspondence with CareFlex or your local CareFlex distributor. This is on a silver foil label on the bar which the top of the Tilt in Space action is attached to. On motorised chairs, the rear valance panel will need to be pulled back to see this bar. On older chairs, the number is on a label behind the top left hand corner of the back cushion. (Always refer to left and right as you are sitting in the chair).

10. Tray

Your HyroTilt can also be fitted with a tray, which can be used to assist in the client's arm positioning; it should never be used as a restraint.

Always ensure that the tray does not interfere with any stoma devices, feeding tubes or similar devices fitted into the client's abdomen.

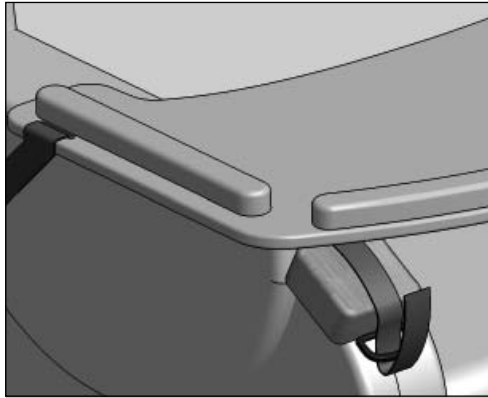

Straps on front of tray fastened through D-rings on the handgrips.

11. Four Point Harness

The four point harness can be used to assist in the client's positioning; it is not to be used as a restraint.

- The four point harness is held in position with a strap from each corner, two straps attach at the client's waist and two over their shoulders.
- These straps are attached to the harness with side-lock buckles, the length of the straps can be adjusted through the buckles.
- Always ensure that the harness is not over tightened and does not interfere with any medical devices implanted in the client's abdomen.

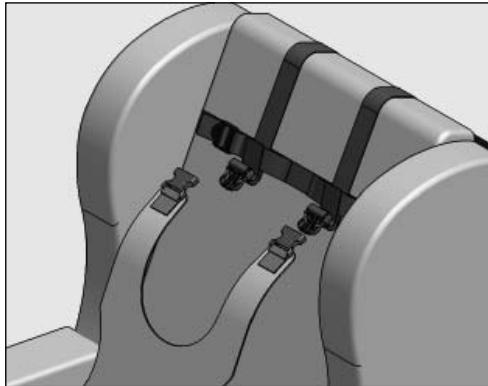

Four point harness to provide support to the upper trunk.

12. Groin Harness

A groin harness can be used to control the client's position; it is not to be used as a restraint:

- The harness consists of a padded cross shape and webbing straps. Two points of the padded cross shape are attached at the junction between the seat and back cushions.
- When seated in the chair, the two loose ends of the harness should be pulled up over the client's thighs and attached to the straps at the rear of the chair.
- The harness can be adjusted through the webbing straps.

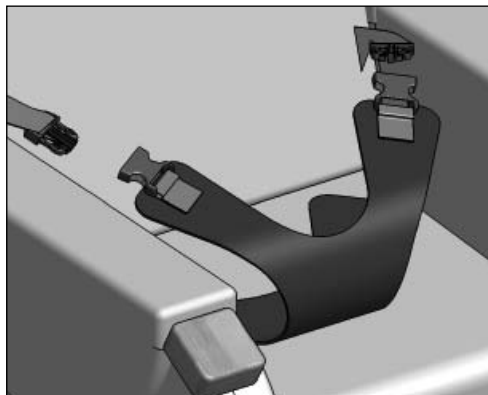

Groin harness to stabilize pelvic position in the back of the seat.

1. Brakes

- To locate the brakes, push the chair forward so that the rear castors swing around and the brakes can easily be accessed.
- Use your foot to press down on the end of the brake lever to lock the castors.
- Gently kick the top of the brake lever to unlock the castors.
- **Always brake the castors before transferring the client on or off the chair.**

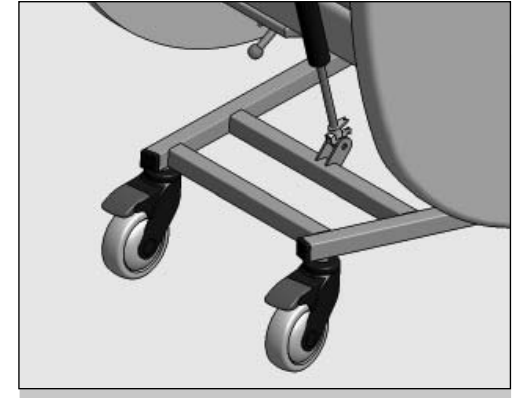

Apply the brakes by pressing down the ends of the blue levers on the rear castors.

2. Seat Depth

Seat Depth is the most important feature for the correct performance of your chair. When set correctly, the client's buttocks should be positioned right back in the seat and there should be a two finger gap between the client's calves and the front of the seat cushion. To adjust seat depth:

- Locate lever at the back left-hand side of the chair.
- Twist lever down and pull/push handle on right hand side until seat depth is in desired position.
- Release the lever and pull the handle until you feel the seat "click" positively into position.
- **Never adjust the seat depth when the client is in the chair.**

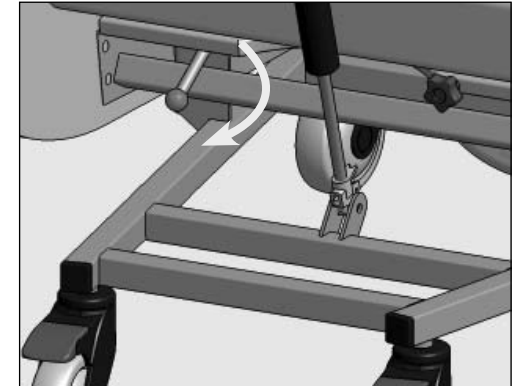

The seat depth release lever is twisted down to release the locking mechanism.

3. Tilt-in-Space

Tilt-in-Space is controlled with the lever on the push handle at the back of the chair:

- Gently pull the lever to release Tilt-in-Space.
- Adjust angle of chair to desired position.
- Release the lever to lock.
- **Do not attempt to raise the client to a standing position when the chair is tilted backwards.**

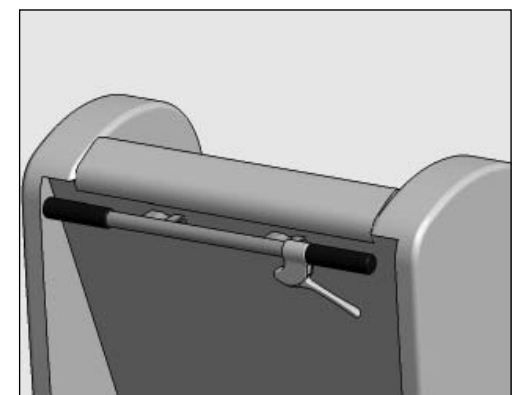

The lever on the right side of the push handle operates the Tilt-in-Space.

4. Leg Elevation

The legrest can be elevated for a more comfortable seating position:

- Pull out the lever on the side of the HydroTilt.
- Lift or lower the legrest to the desired angle.
- Release lever to lock the legrest position.
- **Never leave the client unsupervised in the chair with the legrest elevated.**

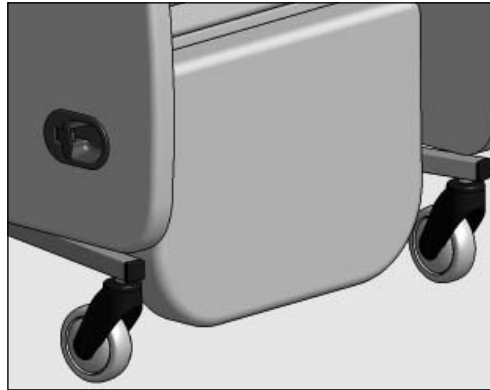

Locate the lever on the right side of the chair to adjust legrest elevation.

5. Legrest Extension & Footplate

The legrest extension and footplate can be attached for clients with a longer lower leg length or who require their feet to be supported; the legrest extension and footplate are fixed into a bracket on the back of the legrest.*

- Pull out the locating pin on the bracket.
- Slide the legrest extension or footplate to adjust it to the desired height.
- Release the locating pin.
- The pin should 'click' into position when the extension or footplate is properly located.

*If your chair does not have a bracket on the legrest one can be easily retro-fitted.

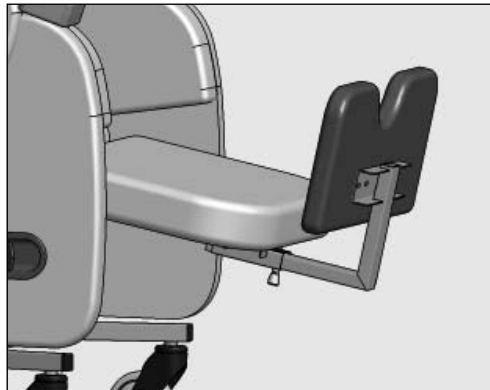

The footplate fits into the bracket on the back of the legrest.

6. Headrests

The headrest should always support as much of the client's head as possible. It can be adjusted up and down via the strap which loops around the push handle and is held in place with Velcro.

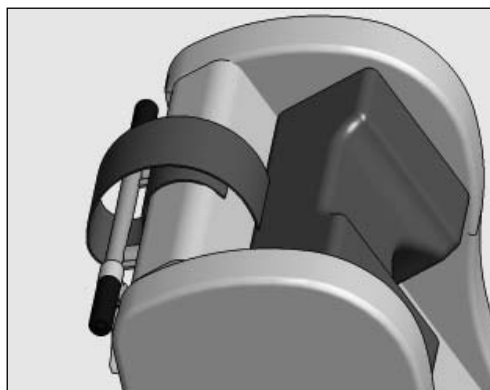

Loop the headrest strap around the push handle.

7. Adjusting Seat Width

Seat width can be easily adjusted by swapping the removable arm cushions. To adjust the arms:

- Gently separate the Velcro holding the arms in place and swap the arms for the most appropriate size.
- The semi-circular curve of the cushion must always be fitted to the outside of the chair.
- When adjusting the seat width always allow a small, equal gap either side of the client for movement.



Swapping the arms for a pair with a different internal thickness allows seat width to be adjusted

8. Pelvic Strap

The lap/pelvic strap length is adjusted by the two part buckle and a 'tri-glide' adjuster:

- To fasten buckle 'click' two halves together.
- To release buckle, press tabs on the sides of buckle and pull two halves apart.
- The Lap/Pelvic Strap is a posture aid; it is not to be used as a restraint. The client must be supervised by suitably trained personnel at all times if they are using a Lap/Pelvic strap.

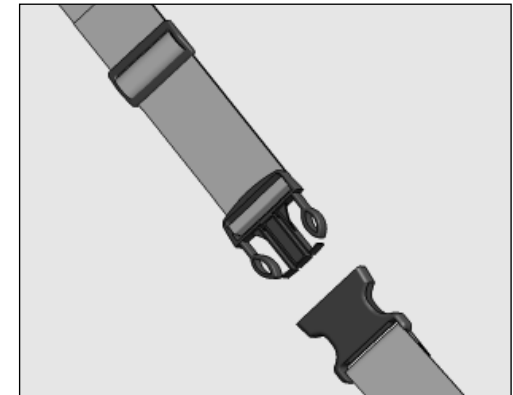

The two halves of the pelvic strap buckle.

9. Motorised Version

If you have a motorised HydroTilt:

- Tilt-in-Space and Legrest elevation are controlled via the hand controller.
- The motorised version is battery operated. Always ensure that the batteries are properly charged before each use.

Please refer to the HydroTilt Accessories User Instructions for full details of charging your motorised HydroTilt



4-button handset for Motorised HydroTilts.